



Aluminum BigBen™ Hand Bender

Catalog Number	Size Thinwall	Size IMC, Rigid	Radius	Fits Bender Handle
960	1/2" (12.7 mm)	—	5" (12.7 cm)	BH-75
961	3/4" (19.1 mm)	1/2" (12.7 mm)	6" (15.3 cm)	BH-75
962	1" (25.4 mm)	3/4" (19.1 mm)	8" (20.3 cm)	BH-100



Aluminum Gardner® Hand Bender

Catalog Number	Size Thinwall	Size IMC, Rigid	Radius	Fits Bender Handle
930B	1/2" (12.7 mm)	—	5" (12.7 cm)	BH-75
931B	3/4" (19.1 mm)	1/2" (12.7 mm)	6" (15.3 cm)	BH-75
932	1" (25.4 mm)	3/4" (19.1 mm)	8" (20.3 cm)	BH-100
933	1 1/4" (31.8)	1" (25.4 mm)	12" (30.5 cm)	BH-125



Iron Hand Bender

Catalog Number	Size Rigid	Size IMC	Radius	Fits Bender Handle
920	1/2" (12.7 mm)	1/2" (12.7 mm)	3-3/4" (12.7 cm)	BH-75
921	3/4" (19.1 mm)	3/4" (19.1 mm)	7" (15.3 cm)	BH-75
922	1" (25.4 mm)	1" (25.4 mm)	8-1/2" (21.6 cm)	BH-100
923	1-1/4" (31.8)	—	13" (33.0 cm)	BH-125

Hand Bender Handles

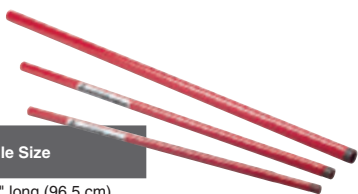

Catalog Number	Handle Size
BH-75	3/4" NPT x 38" long (96.5 cm)
BH-100	1" NPT x 44" long (111.7 cm)
BH-125	1-1/4" NPT x 54" long (137.2 cm)



Hand Benders How To Guide



90° Bends



Measure length of bend (X). Subtract bender deduct (see Table 1) from length (X) and mark this length from the end of the conduit (Y). Line up (Y) with arrow on bender. Bend until 90° bend is formed.

Table 1

Conduit Size	EMT Deduct	Rigid or IMC Deduct
1/2" (12.7 mm)	5" (12.7 cm)	6" (15.2 cm)
3/4" (19.1 mm)	6" (15.2 cm)	8" (20.3 cm)
1" (25.4 mm)	8" (20.3 cm)	12" (30.5 cm)
1 1/4" (31.8 mm)	12" (30.5 cm)	—

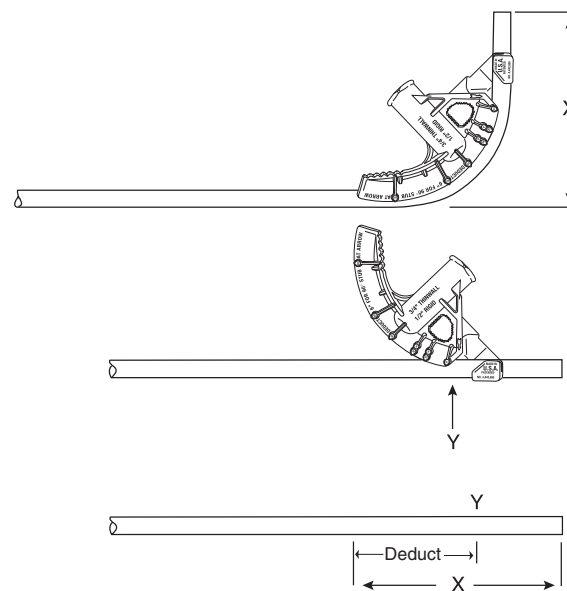

Back-to-Back Bends

Measure and mark distance on the conduit from a fixed point (X), to the back of the 90° bend, point (Y). Align (Y) with (B or ★) on bender and make a 90° bend.

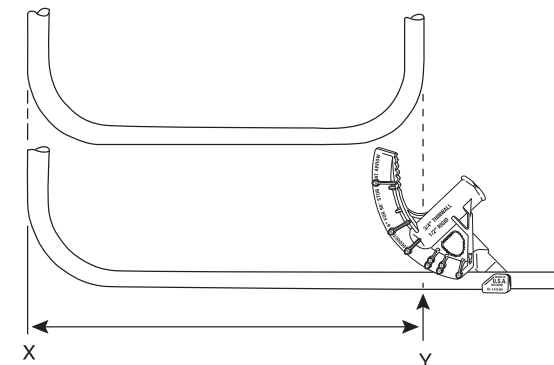

Offset Bends



Measure height of offset (Z) and multiply by a constant multiplier per angle of bend (see Table 2 on next page) to determine distance between bends. Measure length (L) from end of conduit to offset and add shrinkage (see Table 2 on next page). Mark this length on conduit (Y). Subtract distance between bends and mark point (X). Using arrow on bender, make desired bend at point (X). Reverse bender and repeat at point (Y).

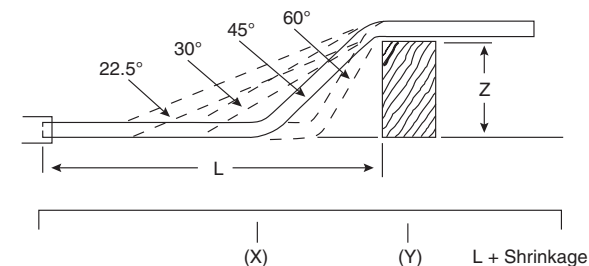

Offset Bend Calculations

3-Point Saddle Bends

Correcting Overbends

Definition of Terms Used

Table 2

Angle of Bend	Constant Multiplier	Shrinkage / Inch (25.4 mm) of Offset Depth
10°	6.0	1/16" (1.6 mm)
22-1/2°	2.6	3/16" (4.8 mm)
30°	2.0	1/4" (6.4 mm)
45°	1.4	3/8" (9.5 mm)
60°	1.2	1/2" (12.7 mm)

(For pre-determined values use Table 3)

This chart is a guide for computing shrinkage. Remember, shrinkage values are only used when working into objects, not away.

Recommended Angle Bends per Offset Depths

Table 3

Offset Depth	Angle of Bend	Distance Between Bends	Conduit Shortens
1" (2.5 cm)	10°	6" (15.2 cm)	1/16" (1.6 mm)
2" (5.1 cm)	22-1/2°	5-1/4" (13.3 cm)	3/8" (9.5 mm)
3" (7.6 cm)	30°	6" (15.2 cm)	3/4" (19.1 mm)
4" (10.2 cm)	30°	8" (20.3 cm)	1" (25.4 mm)
5" (12.7 cm)	45°	7" (17.8 cm)	1-7/8" (47.6 mm)
6" (15.2 cm)	45°	8-1/2" (21.6 cm)	2-1/4" (57.2 mm)
7" (17.8 cm)	45°	9-3/4" (24.8 cm)	2-5/8" (66.7 mm)
8" (20.3 cm)	45°	11-1/4" (28.6 cm)	3" (76.2 mm)
9" (22.9 cm)	45°	12-1/2" (31.8 cm)	3-3/8" (85.7 mm)
10" (25.4 cm)	45°	14" (35.6 cm)	3-3/4" (95.3 mm)



Measure height of offset (D) and multiply by a constant multiplier per angle of bend (see Table 2) to determine distance between bends. Measure length (L) from end of conduit to offset and add shrinkage (see Table 3). Mark this length on conduit (C). Subtract distance between bends and mark point (X). Using arrow on bender, make desired bend at point (X). Reverse bender and repeat at point (Y).

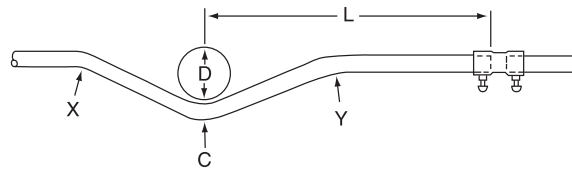

Hickey Bends

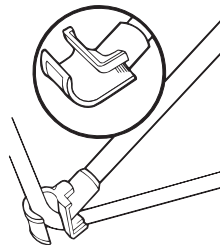

Hickey bends are a series of segment bends (not to exceed 10° per bend) for sharper than standard code radius bends. Bending success with a hickey is directly proportionate to the operator's bending skill.

Because it is flexible, EMT is easy to straighten and will not break if handled as follows. Slip the bender handle over the stub and pull back the desired degree(s) from the bend. For larger conduit sizes, the bender handle can be replaced by a pipe of correspondingly larger diameter or one small enough to fit inside the conduit. Big Ben™ features bend-back channel (see below).

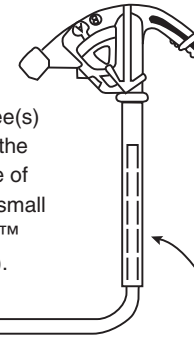

Big Ben™ Features



Industry Standard Style
30° bend when handle is straight up



Bigger Hook
With a 5x durability factor



Bigger Foot Pedal
40% larger



More Foot Room
Allows for a booted foot



Bend-Back Channel
Easily corrects conduit over-bends



Vise-Mate™
Holds conduit while cutting or reaming



Back-to-Back Bend

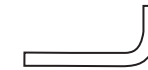

90° Bend



"Dog Leg" Bend or "Kick"

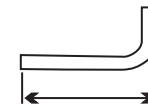

Leg Length



Offsets



Rise or "Stub-ups"



Segment Bend



Concentric Bends