

IMPORTANT: RECEIVING INSTRUCTIONS: Visually inspect all components for shipping damage. If any shipping damage is found, notify carrier at once.

Shipping damage is NOT covered by warranty. The carrier is responsible for all repair or replacement costs resulting from damage in shipment.

SAFETY FIRST

IMPORTANT—USER SAFETY AND PROTECTION: In setting up systems to fit your operations, care must be taken to select the proper components and design to insure appropriate integration with your operations and existing equipment and that all safety measures have been taken to avoid the risk of personal injury and property damage from your application or system.

GB ELECTRICAL CANNOT BE RESPONSIBLE FOR DAMAGE OR INJURY CAUSED BY UNSAFE USE, MAINTENANCE OR APPLICATION OF ITS PRODUCTS. Please contact GB ELECTRICAL for guidance when you are in doubt as to the proper safety precautions to be taken in designing and setting up your particular application. To protect your warranty use only GB/Enerpac hydraulic oil.

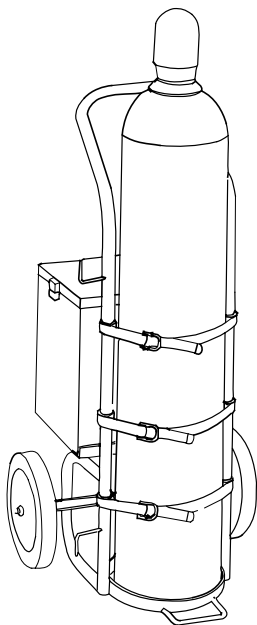

Model JO250 Powr House™
(50 lb. CO₂ System)

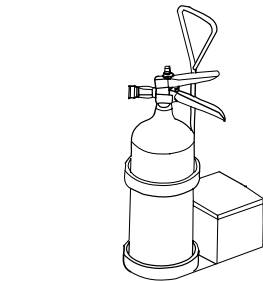

Model JO25C Power Pak II™ (5 lb. CO₂ System with Caddy)

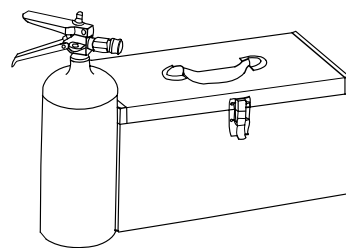

Model JO25 Power Pak I™
(5 lb. CO₂ System)

Model JO220 Powr House™ (20 lb. CO₂ System) not shown.

INTRODUCTION

The GB/Jet Line Carbon Dioxide (CO₂) Conduit Fishing Systems are high pressure tools which are used to place a pull line in most conduit runs from 1/2" through 6" diameter.

These systems are completely self-contained and no other energy source is required. They are convenient to use in remote locations and in new construction where there is no temporary electrical power available or where only one or two conduit runs are required.

Each system consists of five basic components:

- A high pressure gas (CO₂) driving media.
- A control valve to start and stop the gas flow.
- Hose and seal-off to conduct the gas to the conduit and form a seal at the conduit entrance.
- A line carrier to serve as a movable piston that supplies the pulling force.
- Pull line for pulling wire through the conduit or to pull in a rope or cable for large difficult runs.

A thorough understanding of all components and their function and operating precautions is essential for safe and efficient use of the system.

Read all of the instructions before attempting to use the system or blow line in the Conduit.

IMPORTANT SAFETY INSTRUCTIONS



Wear a hard hat, eye protection, and gloves.



When using a carbon dioxide conduit fishing system basic precautions should always be followed. FAILURE TO OBSERVE THESE INSTRUCTIONS COULD RESULT IN SERIOUS INJURY OR DEATH.



Do not discharge a cylinder containing carbon dioxide (CO₂) in a non-ventilated manhole or other non-ventilated areas. Carbon dioxide is relatively inert, but is heavier than air and will displace it and accumulate in depressions and along the floor. Concentrations of

10% (100,000 ppm) can produce unconsciousness and death from oxygen deficiency. Concentrations of 5% may produce shortness of breath and headaches. Provide adequate ventilation.

WARNING

When operating a CO₂ System, do not direct the high pressure CO₂ stream towards any part of the body; serious injury or possible death could occur.

WARNING

All GB/Jet Line Systems are designed to force loose debris of all types out of the conduit by means of a pressurized force. Serious or critical injury could occur to anyone struck by high velocity exiting debris or the line carrier. Warn all personnel to stand clear of the conduit exit prior to commencing pressurization, flush-out procedures, or blowing line into the conduit.

WARNING

Do not hold the seal-off by the rubber cone when discharging CO₂. Maintain a firm grip on the seal-off hose and operating valve at all times while discharging CO₂. The high velocity jet of CO₂ causes a recoil force, and the free end of the hose could whip around possibly causing injury or damage to equipment.

WARNING

During use, portions of the cylinder, valve, hose and seal-off will become very cold as may be noted by frost forming on these parts. Do not touch these areas with bare hands. If bare hands become frozen to the frosted parts, do not pull away—run water over hand and metal part to free it.

CAUTION

When transporting a GB/Jet Line 5 lb. CO₂ System, remove the seal-off and hose assembly,

install the safety pin in the valve handle, and screw down the handle regulating screw to hold the safety pin in place.

CAUTION

Always make sure the 20 lb. and 50 lb. CO₂ cylinders are securely strapped to the cart to

prevent overturning and damage to the cylinder and valve.

When not in use or while being transported, close the cylinder valve on 20 lb. and 50 lb. cylinders, depressurize operating hose assembly and remove it from the cylinder to prevent accidental discharge. Replace the screw on valve cover on 50 lb. cylinders.

CAUTION

With excessive or constant use, the liquid CO₂ in the cylinder may freeze solid into dry ice,

the pressure in the cylinder may drop to zero, and the gas may not flow. If this occurs, allow the cylinder to thaw out at room temperature; the pressure will return to normal. Do not apply heat to the cylinder to speed up thawing. This could raise the cylinder pressure to an excessively high level, causing the cylinder valve safety disc to rupture and discharge the cylinder contents.

If the safety disc ruptures, have it replaced at an authorized fire extinguisher service center, or replace it with a single GB/Jet Line safety disc.

IMPORTANT: Use commercial grade CO₂ only when refilling the CO₂ cylinder. Never, under any circumstances, substitute any gas other than carbon dioxide (CO₂). The cylinder is pressure rated for CO₂ only.

Use only a GB/Jet Line System. GB has incorporated safety features into the CO₂ system; orifice flow restrictions, adjustable flow regulation, low temperature pressure rated hose, and a rupture disc pressure relief system.

Do not substitute any parts or accessories not manufactured by GB/Jet Line on your CO₂ system.

Have the cylinders hydrostatically pressure tested by a qualified local fire extinguisher service center at two year intervals. Under no circumstances should the hydrostatic test intervals exceed five years.

Observe all federal, state and local codes concerning handling, transporting and storing of compressed gas cylinders.

CARBON DIOXIDE (CO₂)

Carbon dioxide may exist in three physical states; solid (dry ice at -109° F), liquid (under pressure) or gaseous CO₂. Only the liquid and gaseous states are useful in conduit fishing.

Carbon dioxide is normally stored in cylinders in liquid form under pressure (838 P.S.I. at 70°F). It will rapidly turn into a high pressure, high velocity gas when the cylinder or operating hose valve is opened. It is this high pressure, high velocity gas that is used to drive the line carrier through the conduit. During the expansion process, portions of the cylinder, valve, hose, and seal-off will become very cold as may be visibly noted by frost forming on these components.

WARNING

Wear gloves, do not touch these areas with bare hands. Bare hands may become frozen to the metal parts.

GB/JET LINE CO₂ CYLINDERS

GB/Jet Line supplies three sizes of CO₂ Cylinders, 5, 20, and 50 lbs., meeting U.S. Department of Transportation (DOT) requirements for compressed gas. Each cylinder bears a neck stamp showing a DOT number indicating the maximum allowable working pressure, serial number, manufacturers identification code, and date of manufacture.

The 5, 20, and 50 lb. sizes indicate the weight in pounds of liquid CO₂ that the cylinder will hold. CO₂ cylinders are supplied filled and ready for use. When a cylinder becomes empty, it may be refilled by most authorized fire extinguisher service centers. The 5 lb. CO₂ cylinders may be refilled from the 50 lb. CO₂ cylinder. A refill connector Model RV5 is required for this operation. See the refilling instructions on page 6.

CAUTION

Do not refill the CO₂ cylinders with air, nitrogen or other gasses. The cylinder is pressure rated for CO₂ use only.

Hydrostatic Pressure Testing—CO₂ cylinders returned to GB/Jet Line for service or repair will be hydrostatically pressure tested for safety if the latest date stamp is more than two years old.

When a cylinder passes the hydrostatic pressure test, the month and year shall be stamped on the cylinder by the approved testing center. Cylinders failing the pressure test must be destroyed.

CO2 Cylinder Specifications

Model No.	1103N	1208	950
Cyl. Size	5 lb.	20 lb.	50 lb.
Weight (full) *	14 lbs.	55 lbs.	154 lbs.
Weight (empty) *	9 lbs.	35 lbs.	104 lbs.
Weight (CO ₂)	5 lbs.	20 lbs.	50 lbs.
Diameter *	5"	8"	9"
Height*	17 ¹ / ₂ "	27"	51"
Valve Type	Squeeze	Rotary	Rotary
Valve Coupling	Ball Lock	Threaded	Threaded
Pressure (70°F)	838 P.S.I.	838 P.S.I.	838 P.S.I.
Maximum Cylinder Working Pressure	See DOT 3 AA rating stamped on cylinder neck		

* Dimensions and empty weight of the cylinder may vary slightly, depending on cylinder manufacturer.

Model 1103N 5 lb. CO₂ Cylinder – The 1103N, 5 lb. CO₂ cylinder, is used in both Power Pak I and Power Pak II conduit fishing kits.

The cylinder is equipped with a "squeeze to operate" hand valve. A thumb screw is used to limit the operating handle movement and regulate the amount of CO₂ dispensed. Adjusting the screw will permit a mere trickle of CO₂ and backing out further will permit full handle travel and a full flow of CO₂ (Refer to Figure 1).

A safety pin inserted through the handle and valve body prevents the handle from being depressed accidentally. The pin should always be in place when the cylinder is not in use or when the cylinder is being transported.

A ball lock quick coupling is provided for attaching seal-off Model 1215 or 1216.

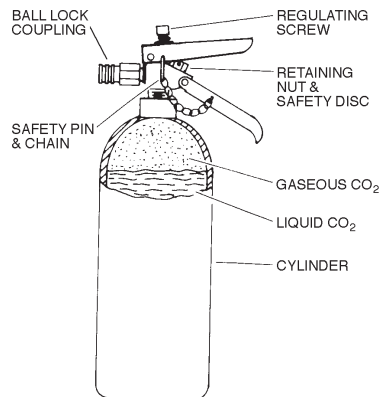

Figure 1
1103N 5 Lb. CO₂ Cylinder

Model 1208 20 lb. CO₂ Cylinder – The model 1208, 20 lb. cylinder, is a cart-transported cylinder weighing approximately 55 lbs. when fully charged with 20 lbs. of CO₂. This cylinder should always remain strapped in the cart to prevent overturning and damage to the cylinder or valve.

The cylinder has a rotary hand valve with a special port thread. The valve requires a matching coupling nut and stem with an O-ring face seal as supplied on Model 1105 CO₂ Operating Valve and Hose Assembly (Refer to Figure 2 and 9).

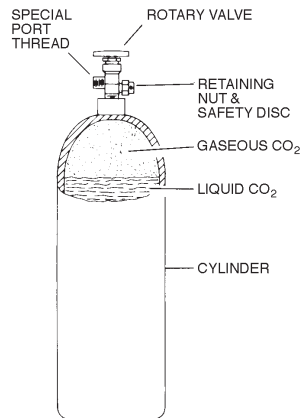

Figure 2
1208 20 Lb. CO₂ Cylinder

Model 950 50 lb. CO₂ Cylinder– The model 950, 50 lb. CO₂ cylinder, is a cart transported cylinder weighing approximately 154 lbs. when fully charged with 50 lbs. of liquid CO₂ (Refer to Figures 3 and 9).

The cylinder is equipped with a rotary hand valve with a special port thread. The valve requires a matching coupling nut and stem with an O-ring face seal as supplied on the Model 1105 CO₂ Operating Valve and Hose Assembly.

A screw on valve safety cover is supplied with the cylinder and should always be in place when the cylinder is not in use or while the cylinder is being transported.

The 50 lb. cylinder may be used as a field refilling supply tank for the 5 lb. cylinder if desired. See refilling instructions on page 6.

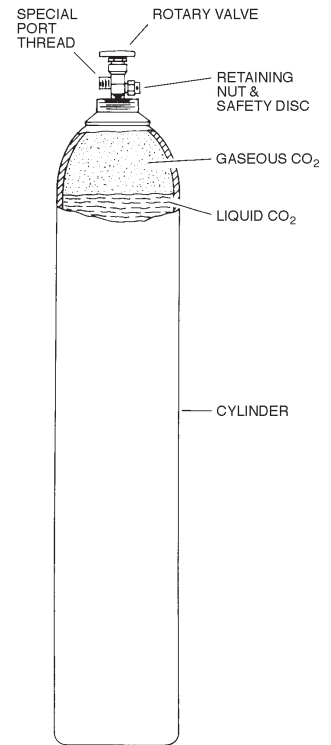

Figure 3
950 50 Lb. CO₂ Cylinder

USE AND OPERATION

With the GB/Jet Line CO₂ system, gas generated from the liquid CO₂ stored in the cylinder is used to propel the line carrier and pull line through the conduit.

When using the CO₂ system, adjust the flow regulating screw on the "squeeze to operate" valve handle on the 5 lb. cylinder or on the 1105 valve and hose assembly. Regulate the flow to a moderate amount sufficient to keep the line carrier moving and the line flowing into the conduit. Develop a light touch and conserve CO₂ (Refer to Figure 4).

CAUTION

The valve handle is very easy to operate when the regulating screw is backed out. Do not attempt to force the handle or damage to the screw and handle could occur.

CAUTION

There is substantial force when the valve is operated and CO₂ is discharged in open air. Point the nozzle in a safe direction and maintain a firm grip on the seal-off frost guard and valve.

CAUTION

Where conduit is run under ground; it may contain water or be subjected to flooding. It may be desirable to blow the water out before blowing a line in the conduit. Because the water will be blown out ahead of the line carrier, take precautions to protect nearby equipment that could be damaged by moisture and sludge (Refer to Figure 16).

BLOWING LINE IN THE CONDUIT

The GB/Jet Line CO₂ system is designed to blow a line in “sealed” conduit such as EMT with compression type couplings, rigid conduit, and plastic conduit with adhesive bonded joints. These types of conduit generally require very little effort to install a pull line with the CO₂ system.

There are some conduit runs that will be difficult or impossible to blow a line in with the CO₂ system, such as:

- Conduit containing hard packed sand, silt, debris, or concrete.
- Conduit with separated joints.
- Conduit with two sizes of duct connected by a reducer coupling.
- Conduit with unsealed set screw couplings.
- Small diameter conduit of several hundred feet with multiple bends.

PREPARATION

It is helpful to know the purpose for which a line is to be used once it has been blown into the conduit. This will aid the user in selecting the appropriate line for the job.

Knowing the approximate length of the conduit will prevent selecting a line that is too short for the run; i.e., if the user wishes to place a light line in a 3/4” conduit with an estimated length of 195 to 200 feet, a 300 ft. power saver line package should be selected for the run. An alternate solution would be to use a 3/4” foam line carrier pulling bulk nylon line. Either selection would insure an adequate length of line.

Selecting the Pull Line – The following list is presented as a guide in selecting a pull line. Users must determine for themselves which best fits their needs.

1. Identification of a conduit run termination where multiple conduit runs originate at a single location.

Recommended Line: Power Saver Line Packages or Bulk Nylon Line.

2. Placing a line in the conduit for use at a later date.

Recommended Line: Small conduit 1/2”, 3/4”, and 1” Power Saver Line Packages, Bulk Nylon Line or PL232. Larger conduit 1 1/4” through 6” Tag-Along Line Packages, PL Series Line PL232, PL235, and PL2310.

3. Pulling in a larger line, rope or steel winch cable.

Recommended Line: Small conduit 1/2”, 3/4” and 1”. Same as 2 above. Larger conduit PL232 or PL235.

4. Pulling wire in conduit.

Recommended Line: PL232, PL235, and PL2310.

SEAL-OFFS

Seal-offs provide a means of making the final connection between the CO₂ operating valve and the conduit, as well as providing a means of feeding pull line into the conduit. The tapered rubber cone that forms the seal at the conduit entrance must be held firmly in the conduit when flushing out water and debris or blowing line in the conduit. Be sure to keep a firm hold on the seal-off hose frost guard while operating unit.

All CO₂ seal-offs are equipped with a male quick disconnect plug that plugs into the operating valve ball lock coupling on the 5 lb. CO₂ cylinder valve or the 1105 operating valve and hose assembly used with the 20 lb. and 50 lb. CO₂ cylinders (Refer to Figure 4).

Connect the seal-off to the 5 lb. CO₂ cylinder valve or the 1105 operating valve as follows:

1. Rotate the valve ball lock coupling sleeve to align notch with embedded ball (Refer to Figure 4).

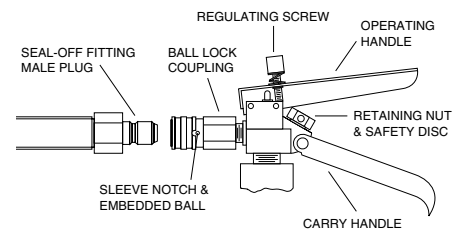

Figure 4
Operating Valve and Seal-Off Coupling

2. Retract the ball lock sleeve.
3. Plug in seal-off connector.
4. Release the sleeve to lock coupling.
5. Rotate sleeve notch away from embedded ball to prevent accidental disconnection.

Disconnect the seal-off from the CO₂ operating valve when threading pull line through the feed port and attaching a line carrier. This step will make the preparation job easier and eliminate the possibility of accidental discharge of CO₂.



WARNING Always maintain a firm grip on the seal-off hose frost guard when the seal-off is connected to the operating valve (See Figure 5). This will prevent the free end from whipping around while discharging CO₂.

Model 1215 Seal-Off – The 1215 Seal-Off with two foot hose is designed for use with the 5 lb. CO₂ cylinder for blowing line in 3/4”, 1/2”, 1”, and 1 1/4” conduit. This seal-off is required for blowing power saver line packages in 1/2”, 3/4”, and 1” conduit. The 1215 seal-off works equally well with the larger GB/Jet Line 20 and 50 lb. systems when connected to the 1105 CO₂ operating valve and hose assembly.

The feed through port will accept bulk nylon line and pull line up to 1/8” diameter.

Model 1216 Seal-Off – The 1216 Seal-Off with two foot hose is similar to the 1215 except for a larger sealing cone. It may be used in conduit sizes 1 1/2” through 2 1/2” diameter and with pull line up to 1/8” diameter.

Model 1206 Seal-Off – The 1206 Seal-Off is designed for use with the larger GB/Jet Line 20 and 50 lb. CO₂ systems. It must be used with the 1105 operating valve and hose assembly. The large rubber cone will fit conduit sizes 1 1/2” through 6”. The feed through port will accept all GB/Jet Line PL Series pull lines PL232, PL235, and PL2310.

OPERATING ACCESSORIES

GB/Jet Line provides specially designed easy-to-use operating accessories for the CO₂ systems that meet most conduit fishing needs.

Model 1105 Operating Valve and Hose Assembly – The 1105 operating valve and 12 ft. hose assembly connects to the 20 or 50 lb. CO₂ cylinder and allows the operator a wide range of movement to reach hard-to-get-to conduit runs.

Connection to the 20 lb. or 50 lb. CO₂ cylinder rotary valve is made with the special thread coupling nut and O-ring face seal on the hose stem. The coupling nut screwed hand tight on the valve port is all that is required for a good seal. When the cylinder rotary valve is opened (opening one or two turns is sufficient) the hose is pressurized up to the operator held hand valve.

Any of the GB/Jet Line CO₂ seal-offs may be threaded up with pull line and line carrier and then connected to the operating valve quick coupling. An adjusting screw is provided on the operating valve handle to limit the valve travel and regulate the flow of CO₂ gas as required by the user.

When not in use, disconnect the seal-off from the operating valve, close the cylinder rotary valve, operate the operating valve to depressurize the hose and remove it from the cylinder valve. Store the hose on the cylinder cart hose hanger hooks or in the cart tool box.

Model 1142 Angle Adapter (See Figure 11) – The 1142 Angle Adapter is provided for use with the 1215 seal-off for installing line in small junction boxes and hard-to-get-to conduit.

To use, remove the rubber cone on the 1215 seal-off and screw the angle adapter on the threaded end of the brass feed through fitting.

Always maintain a firm grip on the seal-off hose behind the feed through fitting to counteract the recoil force of the high velocity CO₂ gas.

Blowing Line Packages through Conduit – This is the easiest method of placing a light weight pull line in the conduit. The line package or seal-off requires no thread up for this operation. However, it is recommended that the seal-off be connected to the operating valve and a preliminary CO₂ flow adjustment be made by alternately operating the valve and adjusting the regulating screw. If more CO₂ flow is required, back out the regulating screw one or two more turns (Refer to Figure 4 and 5).

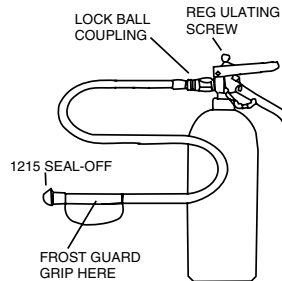

Figure 5
1103N Cylinder with 1215 Seal-Off Connected

Model	Conduit Dia.	Length Ft.
LP2150	1/2"	150'
LP3200	3/4"	200'
LP3300	3/4"	300'
LP3450	3/4"	450'
LP4200	1"	200'
LP4300	1"	300'
LP4450	1"	450'

Table 1
Power Saver Line Packages

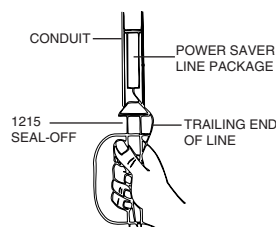

Figure 6
Blowing a Power Saver Line Package In Conduit

WARNING

Always maintain a firm grip on the frost guard of the seal-off hose to prevent it from whipping around.

Power Saver Line Package –

Select the Power Saver line package for size and length of line to fit up to 1" diameter conduit. It is recommended that you flex the package back and forth two or three times to loosen it prior to its use. This will make the line easier to dispense.

Proceed as follows:

1. Pull out approximately two feet of line. Hold on to this trailing end to prevent its loss in the

conduit.

2. Insert the line package in the conduit-foam tip first.
3. Hold the seal-off hose frost guard, force rubber cone firmly in the conduit entrance and give the line package two or three quick spurts of CO₂. The package should be blown through the conduit trailing a line as it goes (Refer to Figure 6 and Table 1).

Model	Length Ft.	Strength Lbs.
LP2206T	400	22
LP2208T	600	22
LP2207T	800	22
LP1704T	1200	22
LP1705T	600	50

Table 2
Tag-Along Line Packages

4. It is recommended that the ends of the line be tied off until ready for use to prevent the end from being accidentally pulled back into the conduit.

Tag-Along Line Package -

Tag-Along Line Packages perform the same function as Power Saver line packages except they are used in 1 1/4" diameter and larger conduit. Tag-Along packages must be used with a line carrier to supply the pulling force.

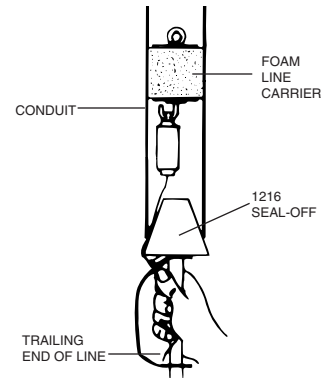

Figure 7
Blowing a Foam Line Carrier and Tag-Along in Conduit

Select the Tag-Along Line Package and a line carrier either foam or inflatable that fits the conduit diameter and proceed as follows:

1. If a foam line carrier is selected, attach the Tag-Along package plastic eye to the foam line carrier hook. Pull out approximately two feet of line and hold on to the trailing end (Refer to Figure 7).
2. Insert the foam line carrier and Tag-Along package in the conduit.
3. Hold the seal-off hose frost guard, force rubber cone firmly in the conduit entrance and squeeze the CO₂ operating valve handle. Continue to apply a flow of CO₂ until line carrier comes out the other end of the conduit. The run time will be longer than for the Power Saver line package because of the larger conduit and greater volume of CO₂ required. However, the run time in 3" and 4" conduit 200 and 300 feet long should be completed in a matter of seconds (Refer to Figure 7).

4. Tie off the ends of the line to prevent it from being accidentally pulled into the conduit.

Inflatable Line Carrier

1. Select an Inflatable line carrier within its conduit diameter range and attach the Tag-Along Line Package to the wire bail. Pull out approximately two feet of line and hold on to the trailing end.

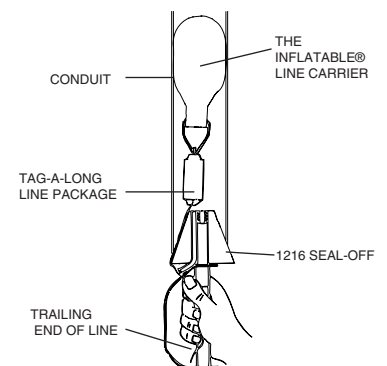

Figure 8
Blowing an Inflatable Line Carrier and Tag-Along in Conduit

- Unfurl the Inflatable line carrier and place it in the conduit-bag portion first (Refer to Figure 8).
- In large conduit (4, 5, and 6" diameter), it may be necessary to point the seal-off nozzle at the plastic sleeve of the Inflatable to achieve initial inflation. This is accomplished by tilting the seal-off in the conduit entrance. Otherwise the collapsed Inflatable may allow the small diameter stream of CO₂ to blow past it.

BLOWING PULL LINE IN THE CONDUIT

All CO₂ systems may be used to blow pull line or nylon line in the Conduit. Position cart transported cylinder and pull line in a location that will allow good access to the conduit entrance (Refer to Figure 9).

Set up as follows:

- Connect the 1105 Operating Valve and hose assembly coupling nut to the CO₂ cylinder valve. Hand tight is sufficient for a good seal.
- Open the CO₂ cylinder rotary valve one or two turns is sufficient to pressurize the hose up to the operating valve.
- Connect the seal-off to the operating valve and make a preliminary operating valve adjustment for moderate flow of CO₂. This is accomplished by backing out the operating valve handle regulating screw and operating the valve until the desired flow of CO₂ gas is obtained (Refer to Figure 9).

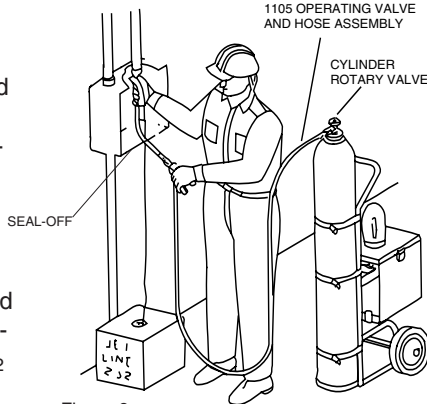

Figure 9
Blowing Pull Lines in Conduit

- Disconnect the seal-off from the operating valve while threading pull line through the feed port and attaching the line

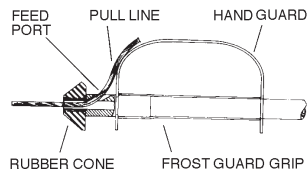

Figure 10
1215 Seal-Off for 1/2", 3/4", 1", and 1 1/4" Conduit

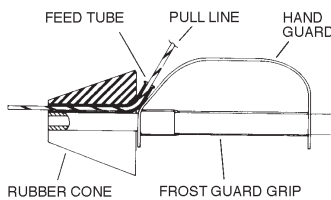

Figure 12
1216 Seal-Off for 1 1/4" to 2 1/2" Conduit

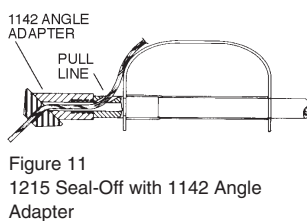

Figure 11
1215 Seal-Off with 1142 Angle Adapter

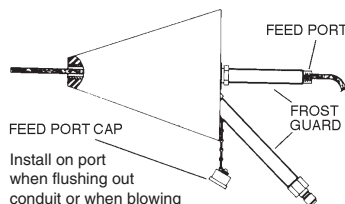

Figure 13
1206 Seal-Off for 1 1/2" to 6" Conduit

- carrier.
- Thread the pull line through the seal-off feed

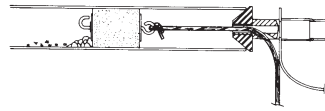

Figure 14
Pull Line Attached to Foam Line Carrier

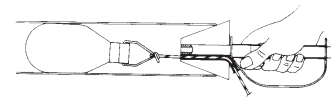

Figure 15
Pull Line Attached to the Inflatable Line Carrier

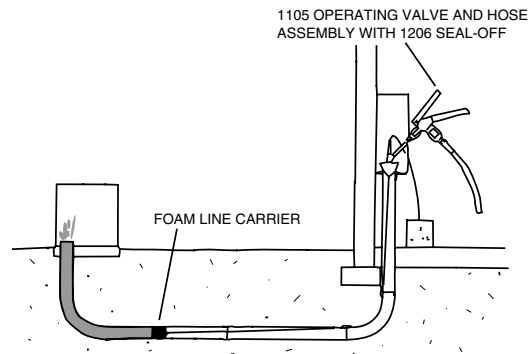

Figure 16
Water Being Pushed Ahead of Foam Line Carrier

port (Refer to Figures 10, 11, 12 and 13).

- Tie the pull line securely to the line carrier to prevent loss in the conduit (Refer to Figures 14 and 15).
- Re-connect the seal-off to the operating valve and insert the line carrier in the conduit.
- Hold the seal-off hose frost guard, force seal-off firmly into the conduit entrance and squeeze the operating valve to start the flow of CO₂. Continue the flow of CO₂ until the line carrier comes out the other end of the conduit. This should take approximately 20 to 30 seconds in a clear 3" or 4" duct that is 300 ft. long. If the duct contains water as shown in Figure 16, the run time will be longer.

REFILLING THE 5 LB CYLINDER

To refill a 5 lb. cylinder from a 50 lb. cylinder, invert the 50 lb. cylinder sufficiently to allow the CO₂ liquid to flow to the top of the valve end of the cylinder. The liquid in the 50 lb. cylinder must cover the valve so that it will drain to the 5 lb. cylinder, otherwise the 5 lb. cylinder will be filled only with CO₂ gas. Weigh the empty 5 lb. cylinder before beginning the refill operation. Refer to step 9.

Figure 17
Refilling the 5 Lb. CO₂ from the 50 Lb. Cylinder

- Invert the 50 lb. cylinder to an angle of approximately 30° with the valve end down. Make sure the 50 lb. cylinder is held securely to prevent rolling or sliding and damage to the cylinder valve.
- Attach the threaded hex nut on the RV5 Refill Connector to the 50 lb. cylinder valve. Finger tight is sufficient.

- Attach the other end of the RV5 to the 5 lb. cylinder valve by plugging it into the quick coupling (Refer to Figure 17).

- Chill the 5 lb. cylinder as follows:

- With the valve on the 5 lb. cylinder in the open position (handle depressed), open the 50 lb. cylinder rotary valve for a full six seconds.
- Close both valves.
- Release trapped pressure in the RV5 by loosening the coupling nut at the 50 lb. cylinder valve.
- Remove the RV5 from the 50 lb. cylinder valve.
- With the RV5 still attached to the 5 lb. cylinder, hold the hose and point it in a safe direction. Operate the 5 lb. cylinder valve and release a short burst (3 to 4 seconds) of CO₂. Expelling CO₂ from the 5 lb. cylinder will cause it to become chilled.

- Re-attach the RV5 to the 50 lb. cylinder.

- Open both cylinder valves and fill the 5 lb. cylinder.

- Close both valves when the audible sound of CO₂ flow stops (about 15-30 seconds).

- Disconnect the RV5 coupling nut from the 50 lb. cylinder valve first. This will bleed the trapped pressure in the hose and prevent damage to the O-ring in the 5 lb. cylinder operating valve.

- Weigh the 5 lb. cylinder. A full cylinder should weigh the total obtained by adding 5 lbs. to the empty weight.

- If the 5 lb. cylinder is underweight, operate the valve as in step 4 and re-chill the cylinder. Re-attach the RV5 to both 50 lb. and 5 lb. cylinders and repeat steps 5, 6, 7, and 8.

- If overweight, leave cylinder on the scales and bleed CO₂ until the correct weight is obtained.

NOTE: After the 5 lb. cylinder has been filled, it may be very cold, and the pressure may be low. It is recommended that the cylinder be stored overnight at room temperature (70°F.). This will insure full working capability of the cylinder.

MAXIMUM NUMBER OF CONDUIT RUNS

The following tables are presented as a guide to the maximum number of conduit runs that can be achieved in "sealed" conduit before refilling of the CO₂ cylinder is required.

"Sealed" conduit for this purpose is considered as EMT with compression type couplings, rigid conduit with threaded couplings and plastic conduit with adhesive bonded joints.

Conditions of the conduit, operating valve adjustment and operator experience will cause the number of runs to vary.

Conduit Diameter	100'	200'	300'	400'
3/4"	75	35	20	17
1"	42	20	13	10
1 1/4"	28	12	8	6
1 1/2"	18	8	6	4
2"	14	5	3	2
2 1/2"	7	3	2	0

Table 3

5 lb. CO₂ Cylinder Maximum Number of Conduit Runs Before Refilling

Conduit Diameter	Conduit Run Length (feet)			
	100'	200'	300'	400'
1/2"	700	345	225	170
3/4"	315	155	103	79
1"	175	86	58	42
1 1/4"	115	57	38	28
1 1/2"	78	38	25	18
2"	44	21	14	10
2 1/2"	28	14	9	7
3"	19	9	6	4
3 1/2"	14	7	4	3
4"	11	5	3	2
5"	7	3	2	
6"	4	2		

Table 4

20 lb. CO₂ Cylinder Maximum Number of Conduit Runs Before Refilling

Conduit Diameter	Conduit Run Length (feet)			
	100'	200'	300'	400'
1/2"	1750	876	582	439
3/4"	796	396	260	196
1"	443	220	145	107
1 1/4"	290	142	95	70
1 1/2"	195	96	64	47
2"	108	52	35	26
2 1/2"	64	32	21	16
3"	44	22	14	11
3 1/2"	33	16	10	8
4"	25	12	8	6
5"	16	8	5	4
6"	11	5	3	2

Table 5

50 lb. CO₂ Cylinder Maximum Number of Conduit Runs Before Refilling.

Conduit Diameter	Conduit Run Length (feet)			
	100'	200'	300'	400'
1/2"	170	80	55	40

REPAIR AND SERVICE INSTRUCTIONS: For repair service and parts contact your nearest GB ELECTRICAL Service Center. The Service Center will provide complete and prompt service on all GB ELECTRICAL products.

PARTS AND SERVICE: For quality workmanship and genuine GB ELECTRICAL parts, select an Authorized GB Service Center for your repair needs. Only repairs performed by an Authorized Service Center displaying the official GB Authorized sign are backed with full factory warranty. Contact GB Electrical (414) 352-4160 for the name of the nearest GB Authorized Service Center.

WARRANTY: GB ELECTRICAL, INC. warrants its products against defects in workmanship and materials for 1 year from date of delivery to user. Chain is not warranted. Warranty does not cover ordinary wear and tear, abuse, misuse, overloading, altered products or use of improper fluid.

WARRANTY RETURN PROCEDURE: When question of warranty claim arises, send the unit to the nearest GB Authorized Service Center for inspection, transportation prepaid. Furnish evidence of purchase date. If the claim comes under the terms of our warranty the Authorized Service Center will REPAIR OR REPLACE PARTS AFFECTED and return the unit prepaid.



GB Electrical, Inc.
An Applied Power Company

6101 N. Baker Road, Milwaukee, WI 53209
Phone: (414) 352-4160 FAX (414) 352-2377

RPS-0095 Rev. A 03/07