



Repair Part Sheet Instruction Sheet

B35 EMT Bender Assembly

RPS-0108 09/00

GB recommends that all kit components be installed to insure optimum performance of the repaired product.

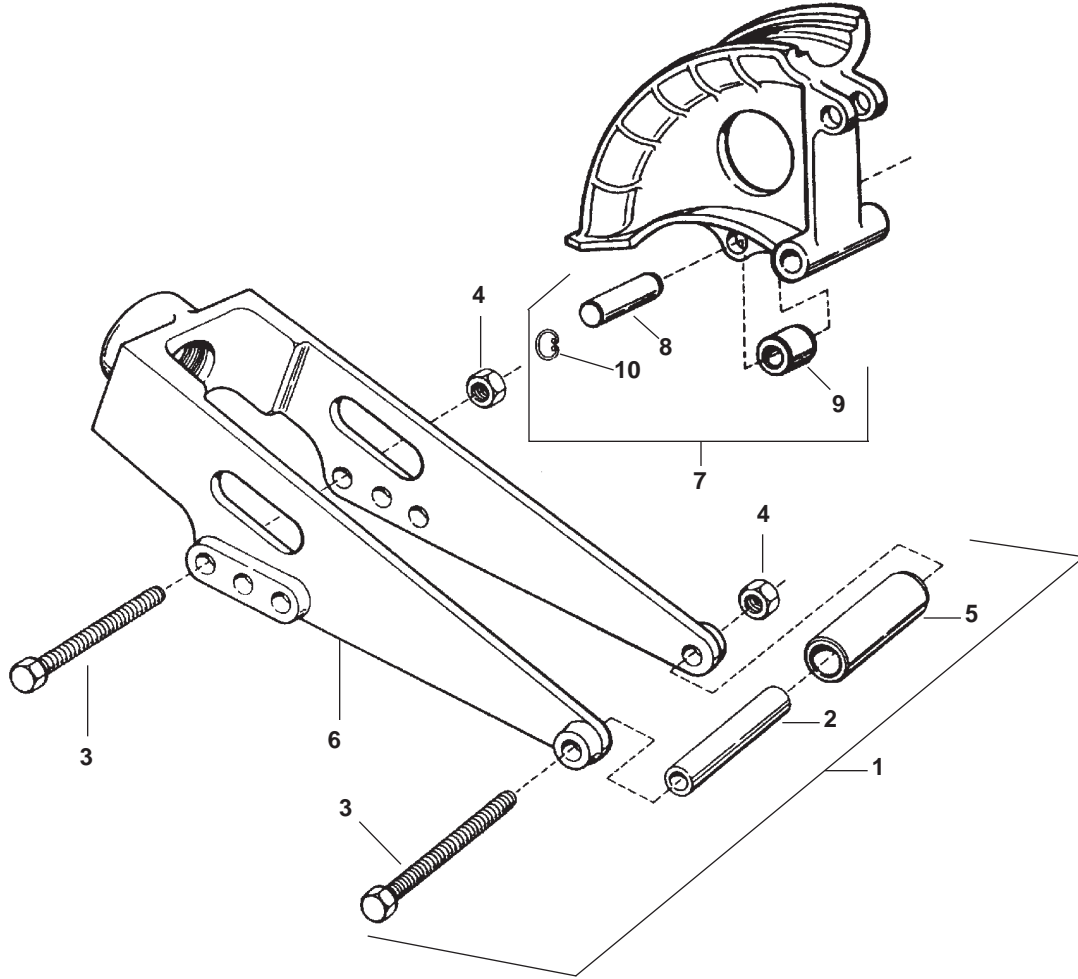

Repair Parts List for B35 EMT Bender Assembly

Item	Part Number	Qty.	Description	Item	Part Number	Qty.	Description
1	BZ501	1	Shoe Roller	4	BZ683	-	Frame Order complete frame assembly
2	BZ502	1	Roller Bushing				
3	B1260046	2	Cap Screw				
				5	B1016123	2	Hex Nut

Repair Parts List for Bending Shoes

Item	Part Number			Qty.	Description
	1 1/4"	1 1/2"	2"		
6	DA12410061	DA12410061	DA12410061	1	Roller Axle Kit
7	Z499	Z689	Z689	1	Roller
8	BZ1346	BZ1347	BZ1348	1	Shoe Segment
9	CN725044	CN725044	CN725044	2	Retainer Ring
10	BZ1185	Not shown	Not shown	1	Saddle
11	A13	Not shown	Not shown	1	Saddle, Threaded

90° STUB-UP INSTRUCTIONS

1. Mark desired turn-up dimension (H) on straight length of thinwall. (See Figure 1.)

NOTE: (H) must be at least 2 inches longer than set-back (S) shown in chart.

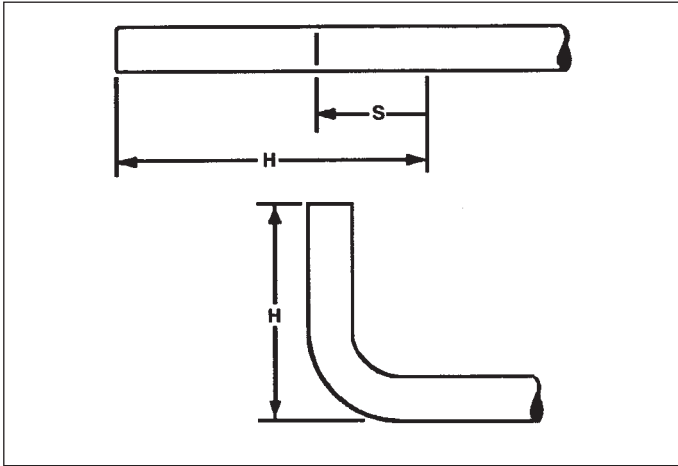

Figure 1

2. Locate the size of thinwall you are using in chart below and obtain dimension (S).

Thinwall Nominal Size (inches)		Set-back (S)
1 1/4"	Actual O. D. – 1.510	8 7/8"
	Centerline Radius of Bend – 7 1/4"	
1 1/2"	Actual O. D. – 1.740	9 3/8"
	Centerline Radius of Bend – 8 1/8"	
2"	Actual O. D. – 2.197	10 3/4"
	Centerline Radius of Bend – 9 1/8"	

3. Measure back dimensions (S) and mark thinwall.
4. Place thinwall conduit in bender so mark (S) aligns with arrow on bending shoe. Proceed to bend, reading angle on shoe at rear edge of bending frame. (Angle on shoe includes approximate spring-back.) (See Figure 2.)

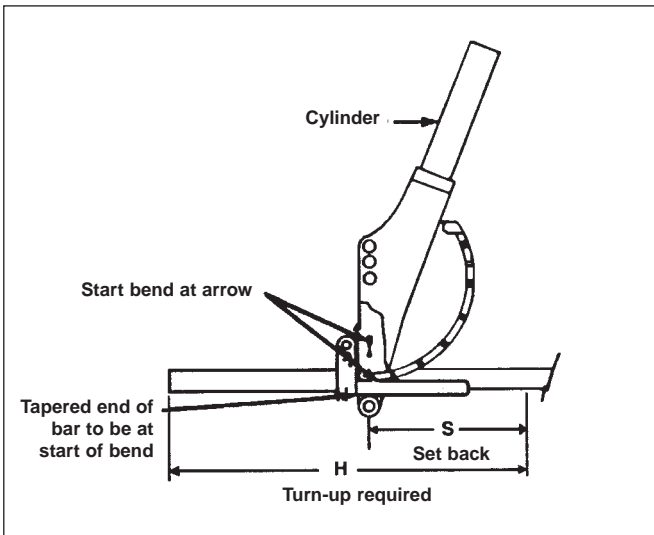

Figure 2

KICK BEND INSTRUCTIONS

1. Use chart (below) applicable to thinwall size used.
2. Using desired kick dimension in (H) column, obtain measurement (M) under the angle of bend desired.
3. Mark off measurement (M) on thinwall as illustrated in Figure 3.
4. Place conduit in bender so mark aligns with arrow on bending shoe. Proceed to bend, reading angle on shoe at rear edge of bending frame. (Angle on shoe includes approximate spring-back.)

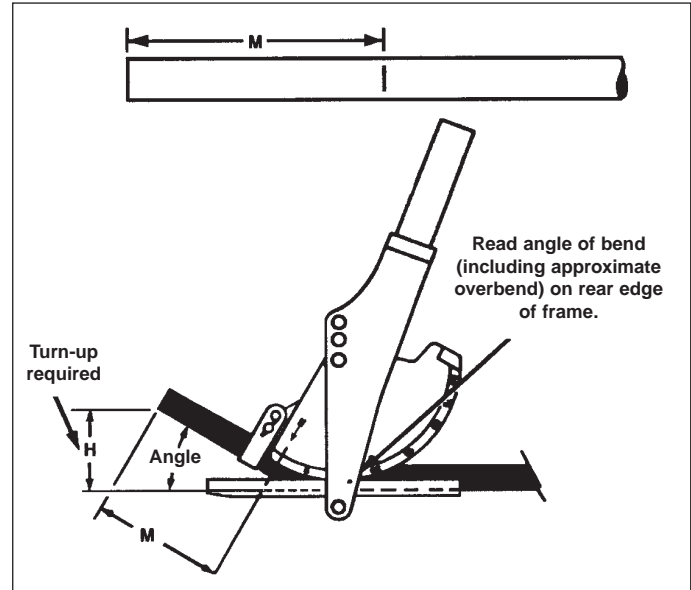

Figure 3

Kick Required (H) Inches	1 1/4" Thinwall Chart			
	Measurement (M) (Inches)			
	15°	30°	45°	60°
2	6	–	–	–
4	13 3/4	4 1/2	–	–
6	21 1/2	8 1/2	5 1/8	–
8	29	12 1/2	7 1/4	–
10	36 1/8	16 1/2	9 7/8	5 1/4
12	44 1/2	20 1/2	12 7/8	8 5/8
14	52 1/8	24 1/2	15 1/4	10 3/8
16	60	28 1/2	18 1/2	12 3/4
18	67 3/4	32 1/2	15	13 7/8
20	75 1/2	36 1/2	24 1/8	17 3/8
22	83 1/4	40 1/2	27	19 3/8
24	91	44 1/2	29 7/8	21 7/8

Kick Required (H) Inches	1 1/2" Thinwall Chart			
	Measurement (M) (Inches)			
	15°	30°	45°	60°
2	4 3/4	–	–	–
4	12 1/2	5 1/4	–	–
6	20 1/4	9 1/4	4 1/4	–
8	27 3/4	13 1/4	7 1/8	3 1/4
10	35 3/8	17 1/4	9 3/4	5 1/2
12	43 1/4	21 1/4	12 3/4	7 7/8
14	51	25 1/4	15 5/8	10 7/8
16	58 3/4	29 1/4	18 1/2	12 1/2
18	66 1/2	33 1/4	21 1/8	14 3/8
20	74 1/4	37 1/4	24	17 1/8
22	82	41 1/4	26 7/8	19 3/8
24	89 1/4	45 1/4	30 1/4	21 3/8

Kick Required (H) Inches	2" Thinwall Chart			
	Measurement (M) (Inches)			
	15°	30°	45°	60°
2	5 ¹ / ₄	—	—	—
4	13	4 ¹ / ₂	—	—
6	20 ³ / ₄	8 ¹ / ₂	4 ⁵ / ₈	—
8	28 ¹ / ₄	12 ¹ / ₂	6 ¹ / ₂	2 ³ / ₈
10	36 ¹ / ₈	16 ¹ / ₂	9 ¹ / ₈	4 ³ / ₈
12	43 ¹ / ₄	20 ¹ / ₂	13 ¹ / ₈	6
14	51 ¹ / ₂	24 ¹ / ₂	15	9 ¹ / ₄
16	58 ¹ / ₄	28 ¹ / ₂	17 ³ / ₄	11 ⁵ / ₈
18	66	32 ¹ / ₂	20 ¹ / ₂	13 ⁷ / ₈
20	73 ³ / ₄	36 ¹ / ₂	23 ³ / ₈	16 ¹ / ₄
22	81 ¹ / ₂	40 ¹ / ₂	26 ¹ / ₄	18 ¹ / ₂
24	89 ¹ / ₄	44 ¹ / ₂	29 ¹ / ₈	20 ³ / ₄

OFFSET BEND INSTRUCTIONS



CAUTION: Be sure the A13 and the BZ-1185 saddles are used together on CS106 cylinder before attempting to bend conduit. Unit will not function if either or both are missing. Damage to the bender will occur.

NOTE: Be sure to make both bends to the same angle:

1. Use chart (page 2 and 3) applicable to thinwall size used.
2. Mark off measurement (M) on thinwall as illustrated. Measurement (M) is distance from end of conduit to start of first bend.

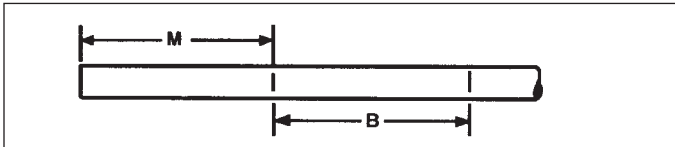

Figure 3

3. Using the same dimension (H) and the same angle of bend, obtain measurement (B) in Offset Chart.

Offset Required (H) Inches	Offset Chart			
	Measurement (B) (Inches)			
	15°	30°	45°	60°
2	7 ¹ / ₄	—	—	—
4	15	7 ³ / ₈	—	—
6	22 ³ / ₄	11 ³ / ₈	8	—
8	30 ¹ / ₂	15 ³ / ₈	10 ⁵ / ₈	—
10	38 ¹ / ₈	19 ³ / ₈	13 ⁵ / ₈	10 ¹ / ₂
12	45 ³ / ₄	23 ³ / ₈	16 ¹ / ₂	12 ⁷ / ₈
14	53 ¹ / ₂	27 ³ / ₈	19 ¹ / ₄	15 ¹ / ₄
16	61 ¹ / ₄	31 ³ / ₈	22	17 ¹ / ₂
18	69	35 ³ / ₈	24 ⁷ / ₈	19 ³ / ₄
20	76 ³ / ₄	39 ³ / ₈	27 ³ / ₄	22 ¹ / ₈
22	84 ¹ / ₂	43 ³ / ₈	30 ⁵ / ₈	24 ¹ / ₂
24	92	47 ³ / ₈	33 ¹ / ₄	26 ³ / ₄

4. Mark off second bend measurement (B) on thinwall as illustrated in Figure 3.

5. Place thinwall conduit in bender, aligning first bend mark (M) with arrow on bending shoe. Proceed to bend, reading angle on rear edge of frame. (See Figure 4.)
6. Rotate thinwall 180 degrees and align second bend mark (B) with arrow on bending shoe. Proceed to bend, reading angle on rear edge of frame. (Angle on shoe includes approximate spring-back.) (See Figure 5.)

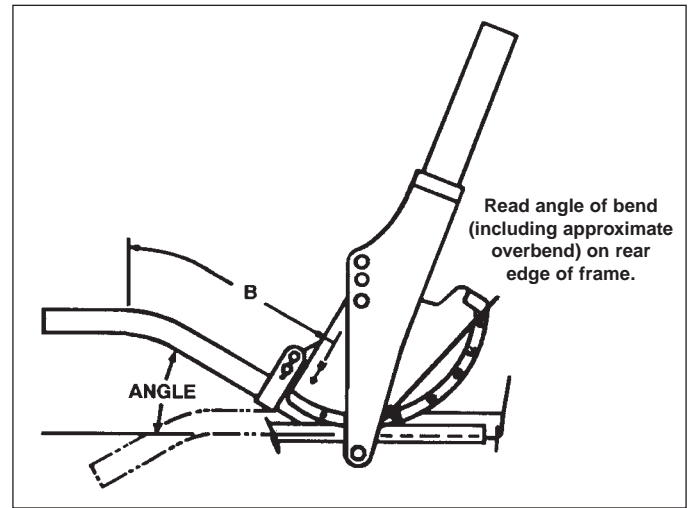

Figure 4

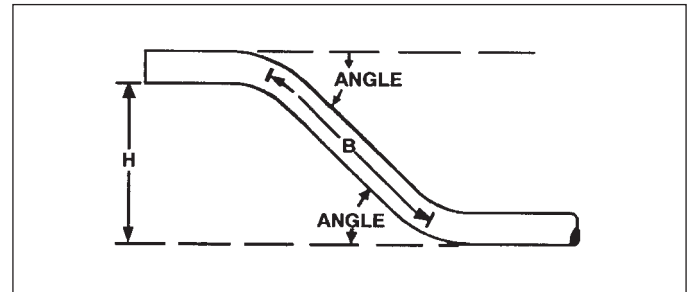

Figure 5

REPAIR AND SERVICE INSTRUCTIONS: For repair service and parts contact your nearest GB ELECTRICAL Service Center. The GB ELECTRICAL Service Center will provide complete and prompt service on all GB ELECTRICAL products.

PARTS AND SERVICE: For quality workmanship and genuine GB ELECTRICAL parts, select an Authorized GB Service Center for your repair needs. Only repairs performed by an Authorized Service Center displaying the official GB Authorized sign are backed with full factory warranty. Contact GB Electrical (414) 352-4160 for the name of the nearest GB Authorized Service Center.

WARRANTY: Gardner Bender warrants its product against defects in workmanship and materials for 1 year from date of delivery to user. Chain is not warranted. Warranty does not cover ordinary wear and tear, abuse, misuse, overloading, altered products or use of improper fluid.

WARRANTY RETURN PROCEDURE: When question of warranty claim arises the user should send the unit to the nearest GB Authorized Service Center for inspection, transportation to be prepaid and evidence of purchase date furnished. If the claim comes under the terms of our warranty the Authorized Service Center will REPAIR OR REPLACE PARTS AFFECTED and return prepaid.



6101 North Baker Road, Milwaukee, WI 53209
Phone: (414) 352-4160 • Fax: (414) 352-2377

RPS-0108 09/00