

To Protect Your Warranty, Use Only Gardner Bender Hydraulic Oil.

GB recommends that all kit components be installed to insure optimum performance of the repaired product.

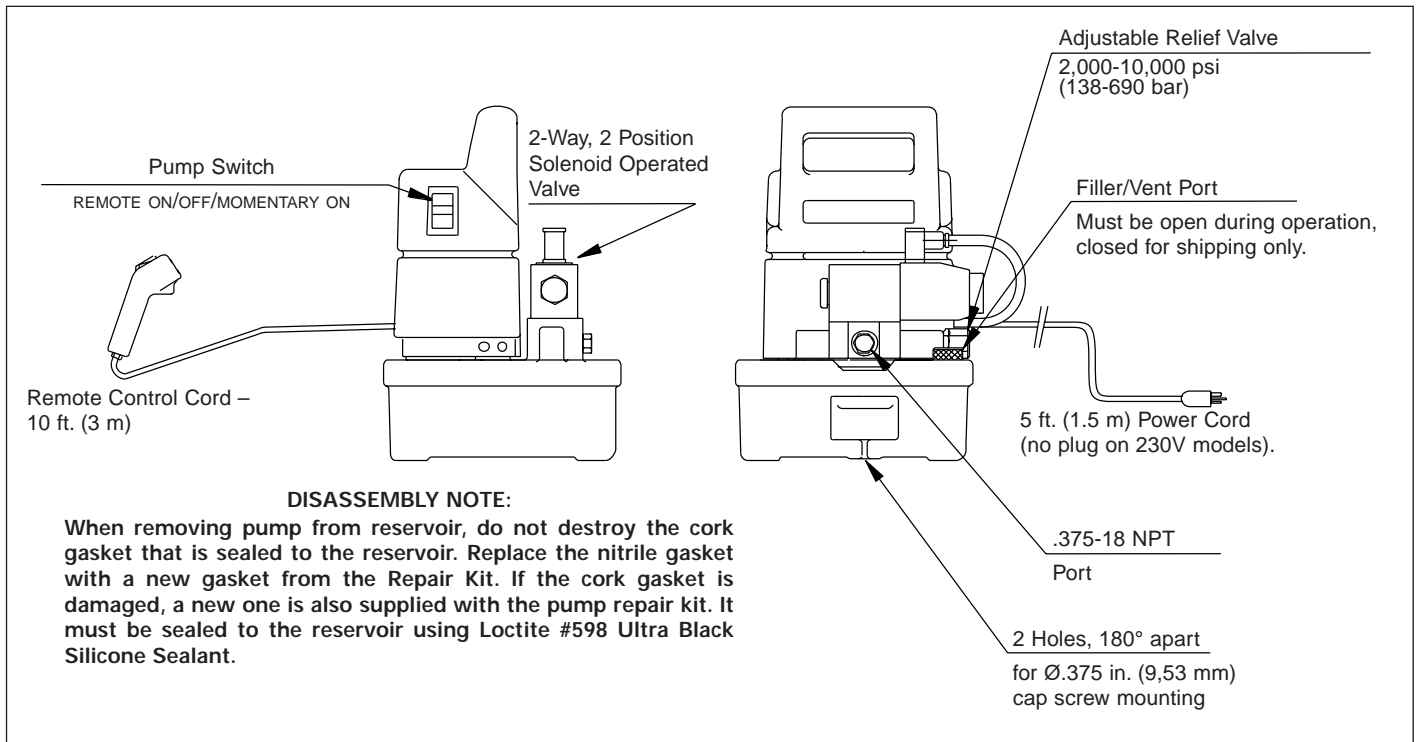

SPECIFICATIONS	PE20D
Maximum Pressure	10,000 psi (700 bar)
Maximum Continuous Pressure	8,500 psi (590 bar)
Electrical Power Source	15 Amp, 115 VAC, 50/60 Hz grounded 1-phase circuit
Motor Rating	1/2 HP (.37 kW) Universal Motor 9 Amps at 10,000 psi (700 bar) and 12,000 RPM, operates to 60-125 VAC
Sound Level	85-89 dBA
Flow Rate	200 in ³ /min (3,4 l/min) from 0 psi to 250 psi (0 to 17,2 bar) 20 in ³ /min (0,34 l/min) from 250 psi to 8,500 psi (17,2 to 590 bar) 18 in ³ /min (0,31 l/min) from 8,500 psi to 10,000 psi (590 to 700 bar)
Maximum Operating Oil Temperature	150°F (65 °C)
Reservoir Size	.75 gallon (2,84 liter)
Usable Oil Capacity	.50 gallon (1,89 liter)

Contents

Figure 1 - Complete Pump	2	Figure 6 - Poppet Valve	8
Figure 2 - Top View	3	Figure 7 - Remote Pendant Assembly	9
Figure 3 - Side View	4	Figure 8 - Solenoid Valve Wire Assembly	9
Figure 4 - Pump Assembly (exploded view)	5	Figure 9 - Electrical Schematic	10
Figure 5 - Top View, Shroud removed	7	Figure 10 - Wiring Diagram	11

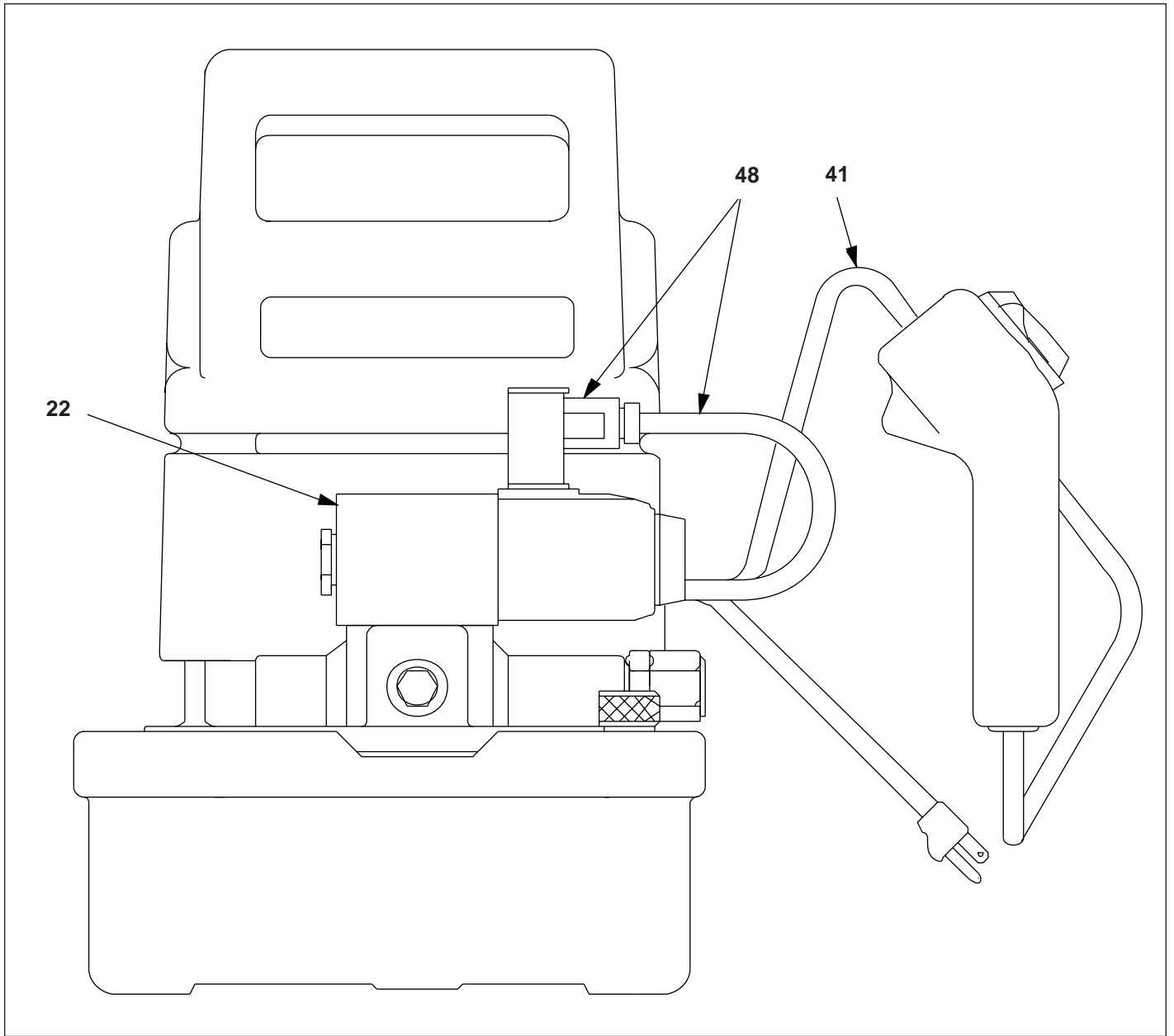

Figure 1 - Complete Pump

Contact GB for replacement nameplate.

Repair Parts List for Figure 1			
Item	Part Number	Qty.	Description
22	VSG2310P	1	115V Poppet Valve Assembly (see Figure 7 for valve assembly)
41	CR881900SR	1	Remote Pendant Assembly (see Figure 8 for cable wiring)
48	DA12343900SR	1	Valve Wire Assembly (see Figure 9 for cable wiring)

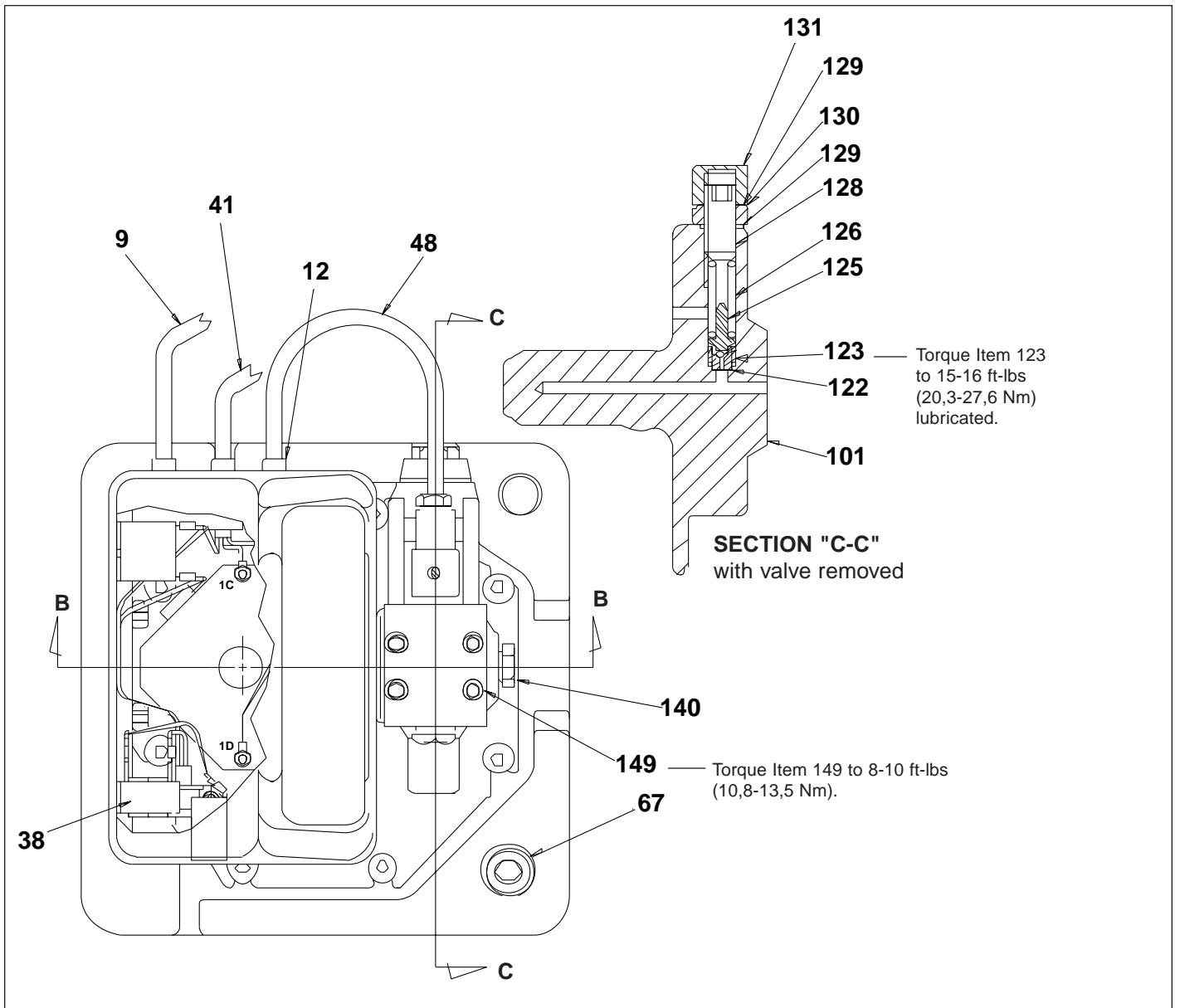

Figure 2 - Top View

Repair Parts List for Figure 2

Item	Part Number	Qty.	Description	Item	Part Number	Qty.	Description
9	DA3709900	1	115V Power Cord	123	★DA5771290	1	Seat
12	CR759291	3	Cord Bushing	125	DC990900	1	Ball Guide
38	E300006	1	115V/24V Transformer	126	★A109164	1	Spring
41	CR881900SR	1	Remote Pendant Assembly	128	DA252028	1	Adjusting Screw
48	DA12343900SR	1	Wire Assembly, to valve	129	★S1167	2	Gasket
67	A1009245	2	Plug	130	CW306055	1	Lock Nut
101	DA12490840SR	1	Pump Manifold	131	CW307055	1	Cap Nut
122	★C846037	1	Gasket	140	R51245-2	1	Plug
				149	B1020028	4	Cap Screw

Note: Item 101 (DA12490840SR), includes Item 121 (DA5999900SR) shown on page 6.

★Items included in and available only as part of Repair Kit PUD1100BK.

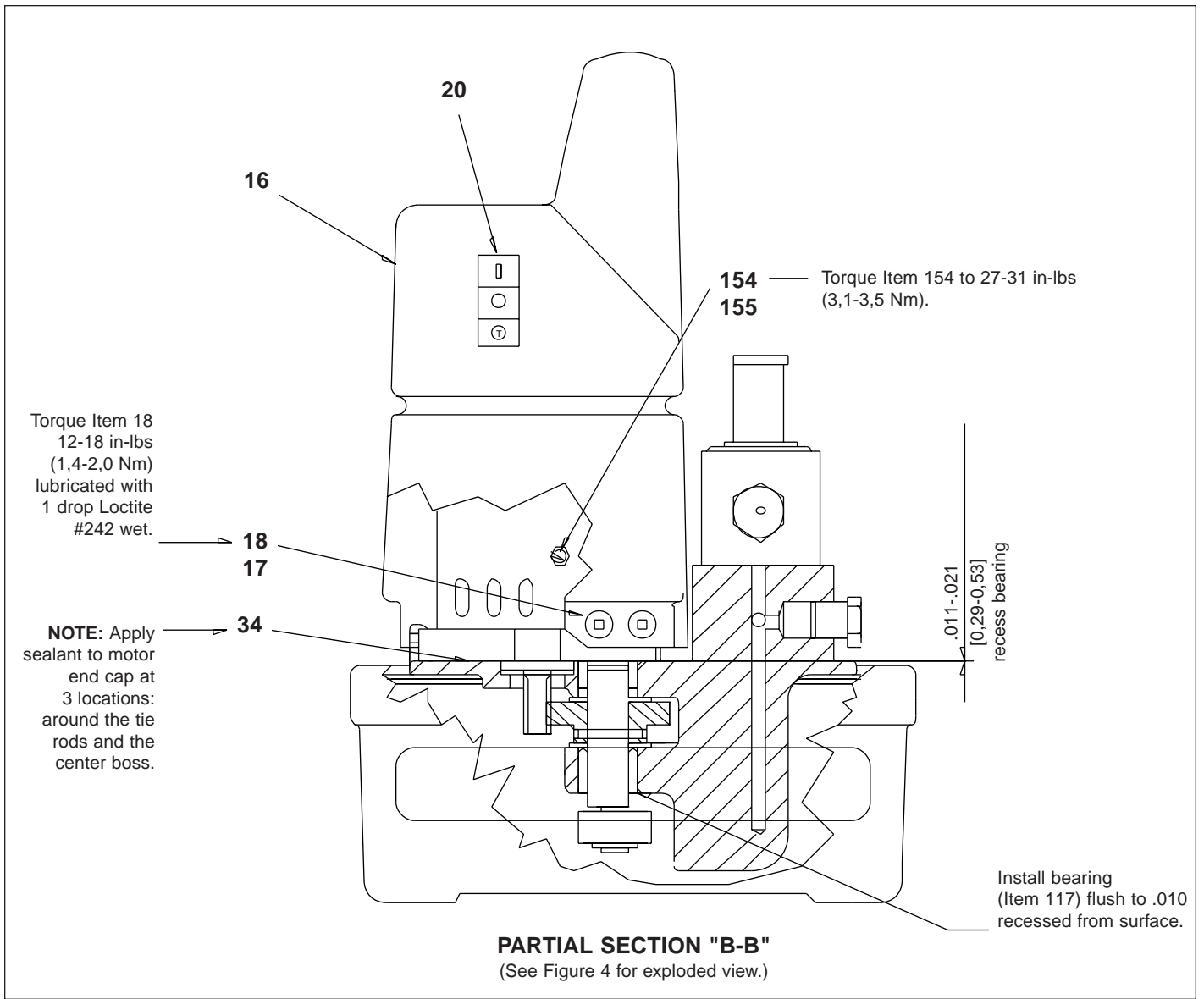

Figure 3 - Side View

Repair Parts List for Figure 3			
Item	Part Number	Qty.	Description
16	DA3763900SR	1	PUD1100/1101B Shroud
17	CW261225	6	Eyelet
18	F866028	6	Machine Screw
20	E1500002	1	Switch
34	CW267885		Loctite #598 Ultra Black Sealant
154	CU876028	3	Screw
155	DA3585186	3	Spacer

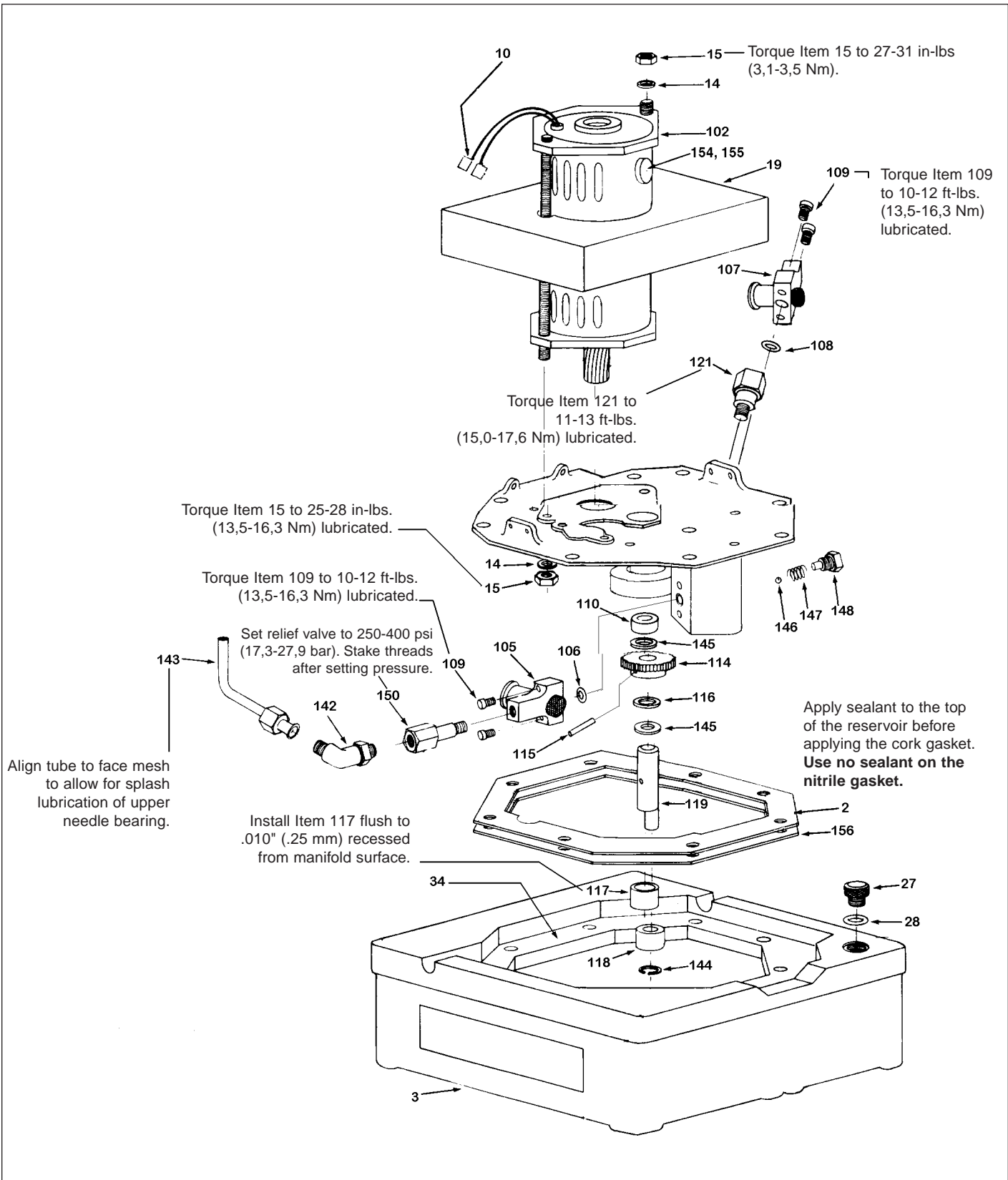

Figure 4 - Pumping Assembly

Repair Parts List for Figure 4			
Item	Part Number	Qty.	Description
1	★DA12088167	1	Gasket (includes 156)
3	DA1910900SR	1	.75 Gallon Reservoir
10	DA3776006	2	Pin
14	DA15066	4	Lock Washer
15	B1018121	4	Hex Nut
19	CW259298	1	Baffle
27	DA608024	1	Vent Plug
28	★B1906503	1	O-ring
34	CW267885		Loctite #598 Ultra Black Sealant
102	CW179259	1	115V Electric Motor
105	CW298950SR	1	.53 Piston Block Assembly
106	★B1007503	1	O-ring
107	CW299950SR	1	.24 Piston Block Assembly
108	★B1012803	1	O-ring
109	B1008028	4	Screw
110	CW252107	1	Bearing
114	CW301228	1	Driven Gear
115	★1097057	1	Spring Pin
116	★CW199107	1	Bearing
117	CW251107	1	Bearing
118	CW302107	1	Bearing
119	CW303104	1	Shaft
121	DA5999900SR	1	Relief Valve
142	DA1011096	1	Elbow
143	DA261268	1	Tube
144	★CW467044	1	Retaining Ring
145	★DA445107	2	Bearing
146	★B1007016	1	Ball
147	★DA1564110	1	Spring
148	DC433950	1	Plug Assembly
150	DA610900SR	1	Relief Valve Assembly
154	CU876028	3	Screw
155	DA3585186	3	Spacer
156	DA12089167	1	Gasket
★ Items included in and available only as part of Repair Kit PUD1100BK.			

Replacement Brushes for Electric Motors		
Part Number	Quantity	Description
DA9655380	1 Set	Brush Set for 115V Models
DA9657020	1 Set	Brush Cap

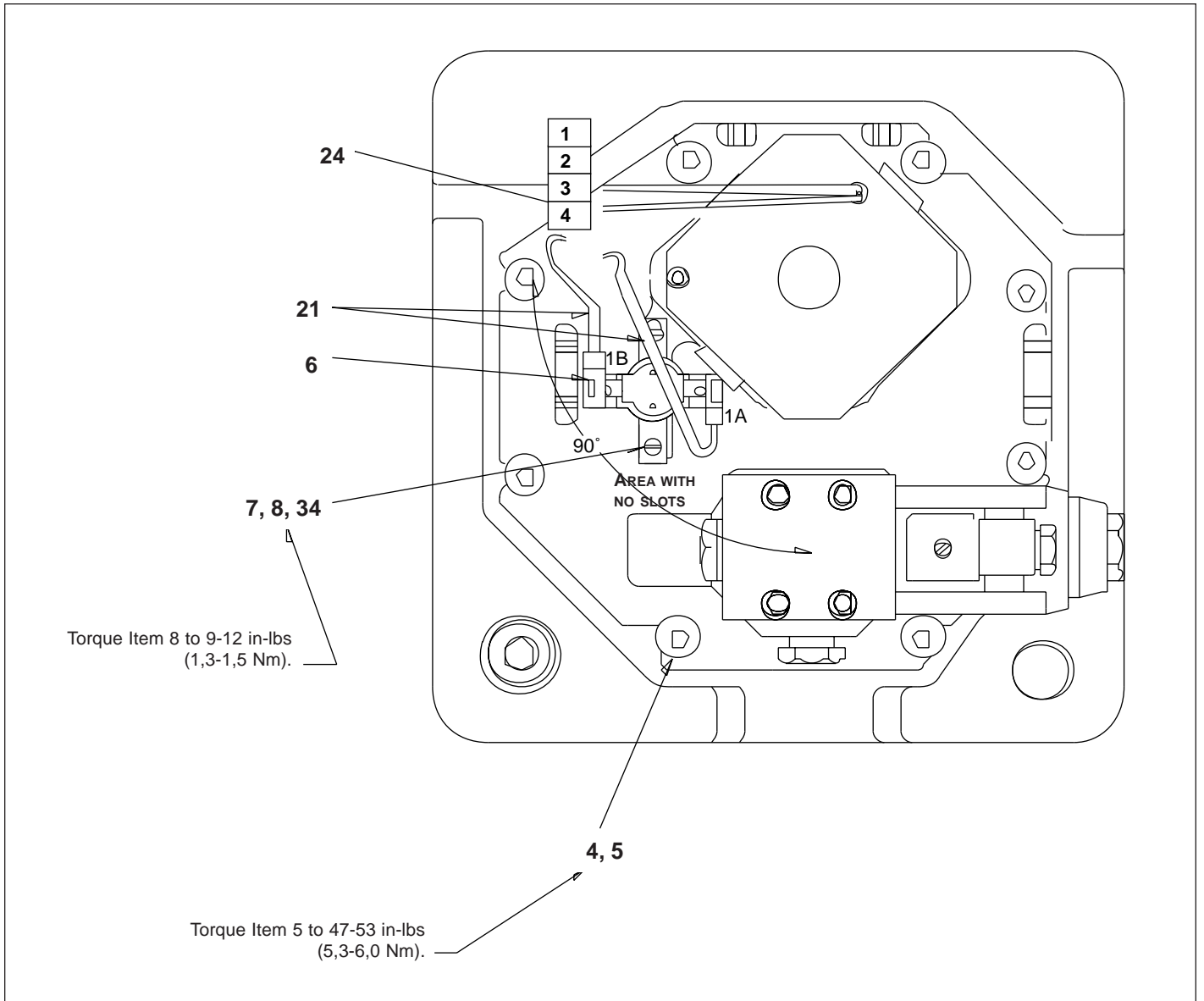

Figure 5 - Top View, Shroud Removed

Repair Parts List for Figure 5			
Item	Part Number	Qty.	Description
4	DA6954167	8	Gasket
5	B2521028	8	Button Head Cap Screw
6	E1100004	1	Thermostat
7	C701222	2	Washer
8	F658028	2	Pan Head Machine Screw
21	DA3712900SR	2	Wire Assembly
24	DA11540380	1	Plug
34	CW267885		Loctite #598 Ultra Black Sealant

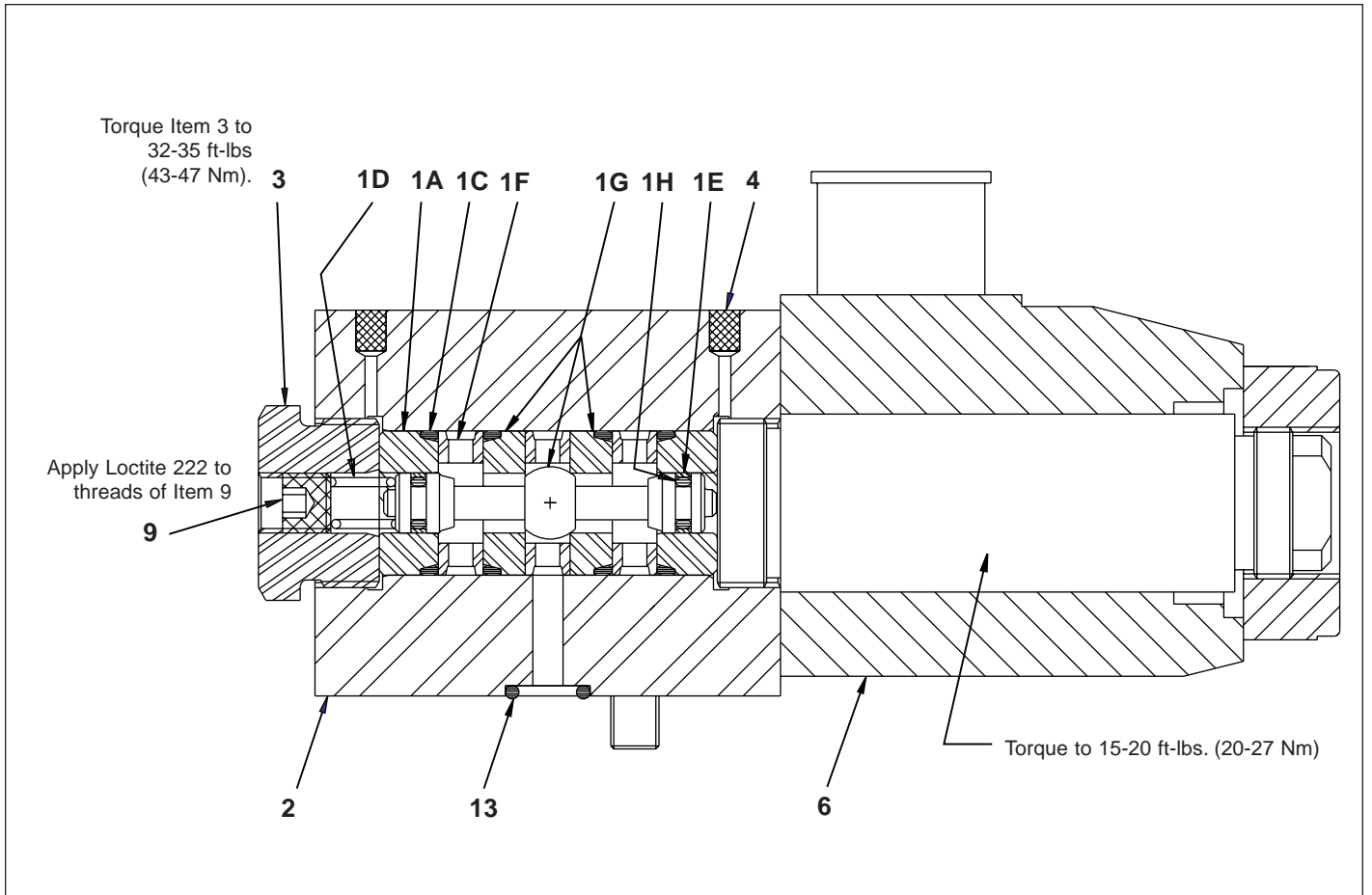

Figure 6 - Poppet Valve

Repair Parts List for Figure 6			
Item	Part Number	Qty.	Description
1	DA5792949SR	1	Valve Stack (includes items 1A-1H)
1A	★	2	Bushing
1C	★	4	O-ring
1D	★	1	Comp. Spring
1E	★	2	Glyd. Spring
1F	★	1	Seat Spacer
1G	★	1	Poppet Set
1H	★	2	O-ring
2	DA4393190	1	Valve Body
3	DA5421009	1	Valve Plug
4	DA4390118	1	Valve Block
6	DA4405900	1	115 V Solenoid Assembly
9	PA1417027	1	Set Screw
13	B1011803	3	O-ring

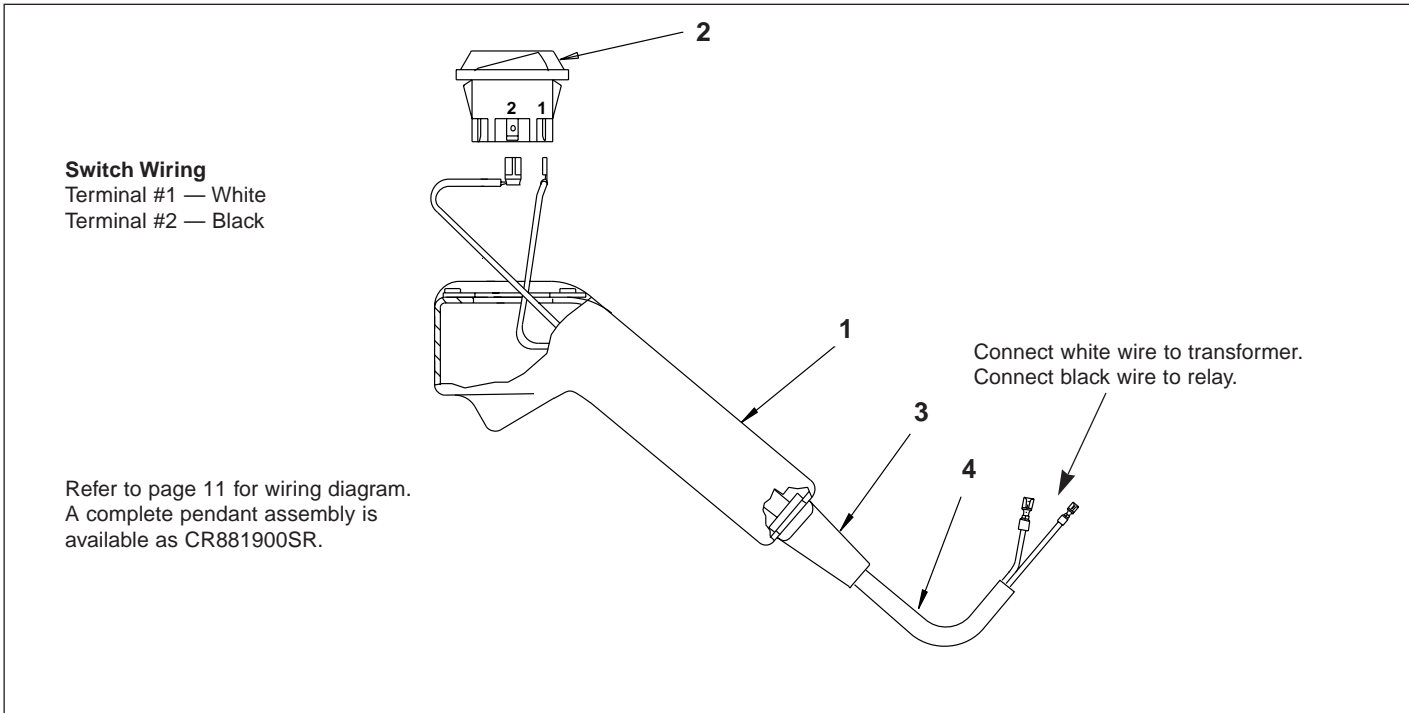
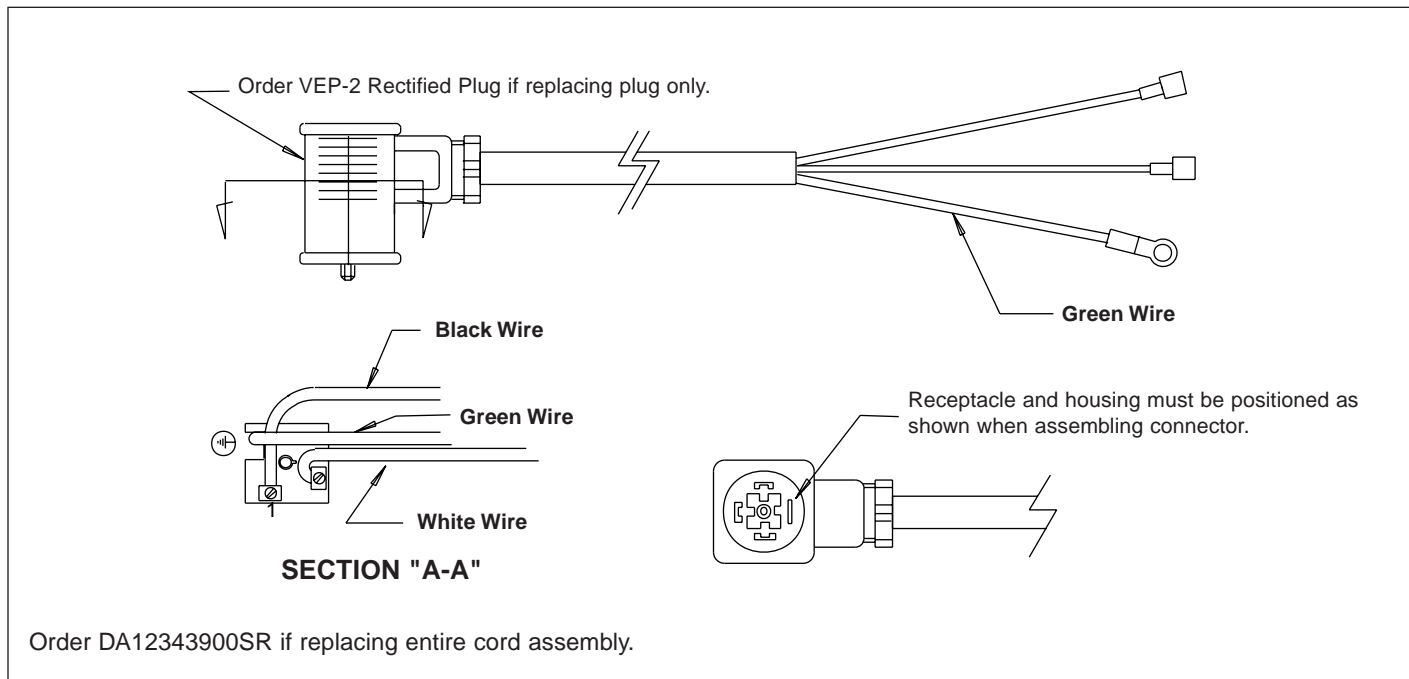

Figure 7 - Remote Pendant Assembly

Repair Parts List for Figure 7							
Item	Part Number	Qty.	Description	Item	Part Number	Qty.	Description
1	CU598190	1	Pendant Body	4	CR880950SR	1	Wire Assembly (includes Item 3)
2	CU911372	1	Switch				
3	DA1568007	1	Strain Relief				



Order DA12343900SR if replacing entire cord assembly.

Figure 8 - Solenoid Valve Wire Assembly

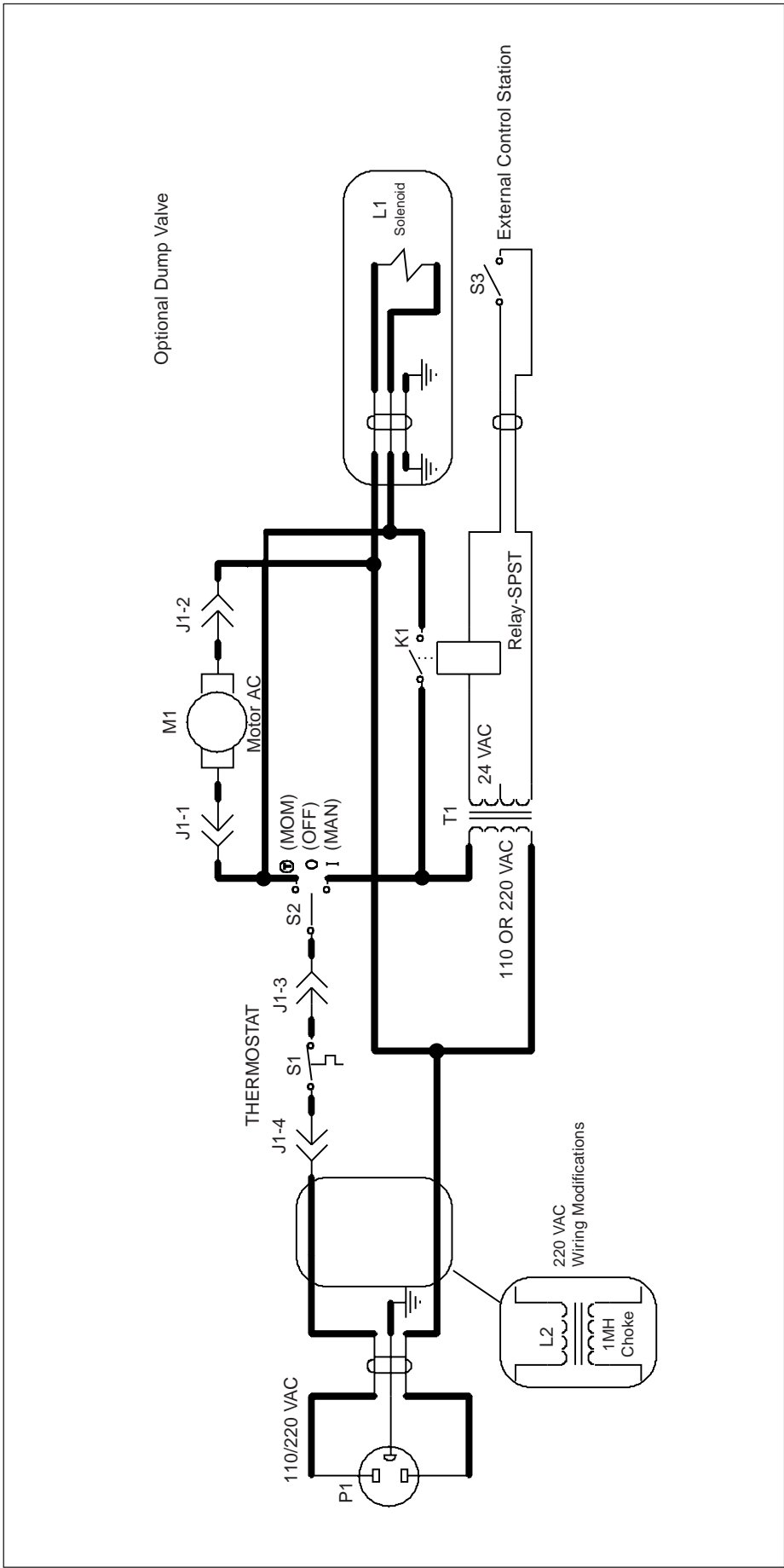

Figure 9 - Electrical Schematic

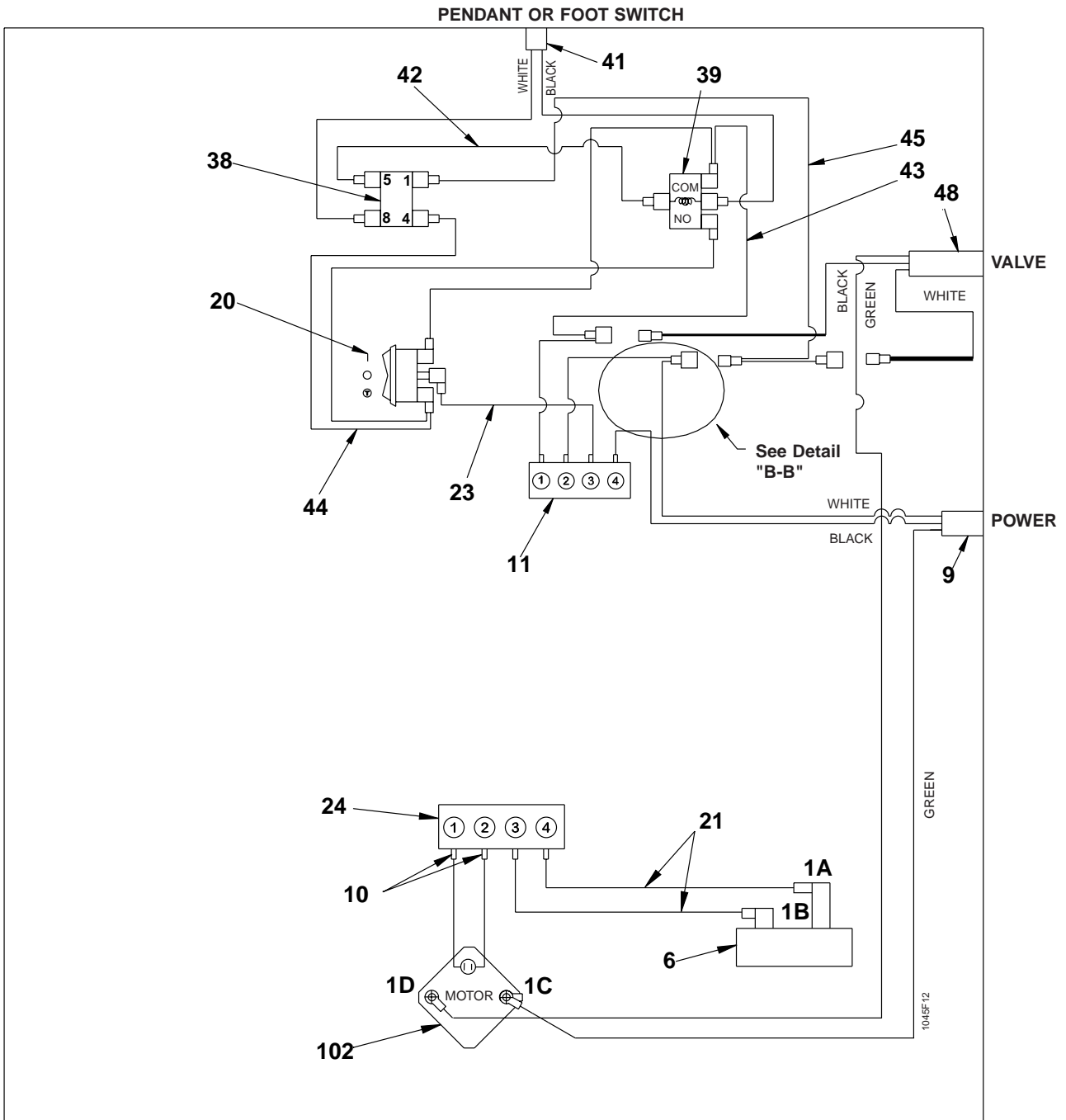

Figure 10 - Wiring Diagram

Repair Parts List for Figure 10							
Item	Part Number	Qty.	Description	Item	Part Number	Qty.	Description
6	E1100004	1	Thermostat	39	E1300008	1	Relay
9	DA3709900SR	1	115V Power Cord	41	CR881900SR	1	Remote Pendant Assy.
10	DA3776006	2	Pin	42	DA1973900SR	1	Wire Assembly
11	DA11539380	1	Receptacle	43	DC2082900	1	Wire Assembly
20	E1500002	1	Switch	44	DA1975900SR	1	Wire Assembly
21	DA3712900SR	2	Wire Assembly	45	DC2083900	1	Wire Assembly
23	DA3711900SR	1	Wire Assembly	48	DA12343900SR	1	Wire Assembly
24	DA11540380	1	Plug	102	CW179259	1	115V Motor
38	E300006	1	115V/24V Transformer				

REPAIR AND SERVICE INSTRUCTIONS: For repair service and parts contact your nearest GB ELECTRICAL Service Center. The GB ELECTRICAL Service Center will provide complete and prompt service on all GB ELECTRICAL products.

PARTS AND SERVICE: For quality workmanship and genuine GB ELECTRICAL parts, select an Authorized GB Service Center for your repair needs. Only repairs performed by an Authorized Service Center displaying the official GB Authorized sign are backed with full factory warranty. Contact GB Electrical (414) 352-4160 for the name of the nearest GB Authorized Service Center.

WARRANTY: GB ELECTRICAL, INC. warrants its product against defects in workmanship and materials for 1 year from date of delivery to user. Chain is not warranted. Warranty does not cover ordinary wear and tear, abuse, misuse, overloading, altered products or use of improper fluid.

WARRANTY RETURN PROCEDURE: When question of warranty claim arises the user should send the unit to the nearest GB Authorized Service Center for inspection, transportation to be prepaid and evidence of purchase date furnished. If the claim comes under the terms of our warranty the Authorized Service Center will REPAIR OR REPLACE PARTS AFFECTED and return prepaid.



6101 N. Baker Road, Milwaukee, WI 53209
Phone: (414) 352-4160 • Fax: (414) 352-2377

RPS-0145 09/00