

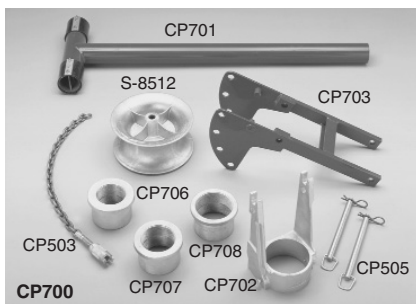

Repair Parts Sheet

CP8000, CP8000D CP8003, CP8006 Powered Cable Pullers

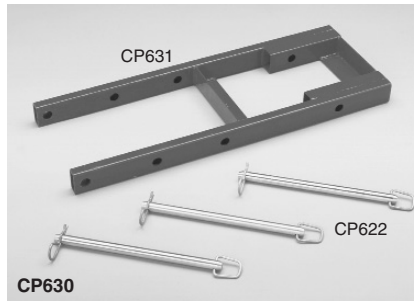
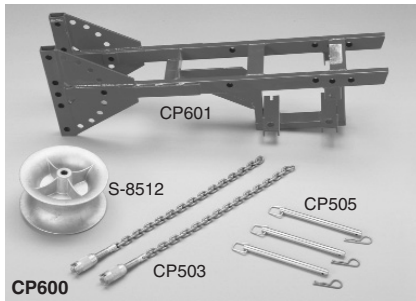

Contents of CP8003 Powered Cable Puller

See chart below for contents of CP8000, CP8000D and CP8006 sets.

Contents of Powered Cable Puller Sets							
Catalog Number	Description	Catalog No.	Description	Components			
				Quantity Per Set			
				CP8006	CP8003	CP8000	CP8000D
CP800	Power Head Assembly includes	CP801	Power Head and Base Mounting Bracket	1 1	1 1	1 1	1 1
CP600	Conduit Frame & Sheave Adapter Assembly	CP503 CP505 CP601 S-8512	2" Chain Assembly 8" Lock Pins Conduit Frame Adapter 12" Sheave	2 3 1 1	2 3 1 1	2 3 1 1	2 3 1 1
CP630	Boom Extension Kit	CP622 CP631	10" Lock Pins Boom Extension	3 1	3 1	3 1	- -
CP700	Puller Base Extension Kit	CP503 CP505 S-8512 CP701 CP702 CP703 CP706 CP707 CP708	2-ft Chain Assembly 8" Lock Pins 12" Sheave Puller Base Extension Coupling Clamp Adjustable Pipe Adapter 3" Conduit Coupling 3½" Conduit Coupling 4" Conduit Coupling	1 2 1 1 1 1 1 1 1	1 2 1 1 1 1 1 1 1	1 2 1 1 1 1 1 1 1	- - - - - - - - -
	Accessories	CP709 CP1002 HS-8512 CM16	6" Lock Pin Rope Steel Stand 12" Cable Sheave w/hook Metal Case with CM44 casters	1 1 1 1	1 1 1 1	1 - 1 1	- - - 1
	Pulling Rope	RST-7530 RST-7560	Double Braided Rope (¾" x 300 ft. Spool) Double Braided Rope (¾" x 600 ft. Spool)	- 1	1 -	- -	- -

Power Head Identification

There has been **three** significant changes in the power head since 1976. Outlined below are identifying features and major changes for each model. The following pages contain parts lists and drawings for each specific model.

CP500 Produced 1976 - June 1985

Identified from other models by:

- A. Machined aluminum motor housing with round vent holes.
- B. Exposed plastic brush caps.
- C. Overall length 25".
- D. Motor attached to gear housing with left hand threads.

CP500-1 Produced June 1985 - August 1990

Identified from other models by:

- A. Motor housing painted gray with rectangle vent holes.
- B. Overall length 26½".

Major changes from previous model:

- 1. Motor changed to permanent magnet design, requiring redesign of gear housing. Internal gear case components, bearings, shaft and capstan are same as previous model.
- 2. Load meter strap change due to change in motor diameter.

CP800 Produced August 1990 - Present

Identified from other models by:

- A. Power head mounted on welded steel bracket by circular flange and eight capscrews.
- B. Steel capstan
- C. Overall length (excluding carry handle) 23½".

Major changes from previous model:

- 1. Mounting bracket change from cast aluminum to steel weldment.
- 2. Complete redesign of gear case including gear sets, shafts, housing and capstan.
- 3. Motor armature redesign.

Cross Reference Replacement Parts for Power Head

Description	CP500	CP500-1	CP800
Power head less mounting bracket	CP501*	CP501-1*	CP801
Mounting bracket	CP502	CP502	CP802
Capstan kit	CP508	CP 508	CP806
Handle kit	_____	_____	CP20
Load meter assembly	CP10**	CP10	CP10
Motor	Obsolete	DA3231900	Sold as separate components

* Not Available

** Requires Strap P/N CA1068001

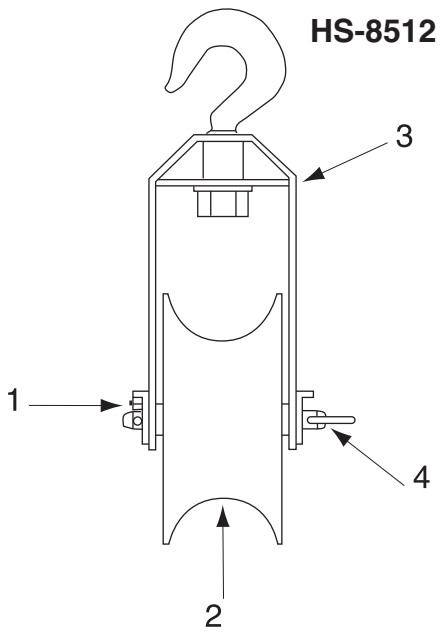

HS-8512

Part Numbers for HS-8512

Item No.	Description	Qty.	Part No.
1	Clip (Hair Pin)	1	CF611058
2	Sheave	1	S-8512
3	Frame	1	H-8512
4	6" Pin Assembly	1	CP709

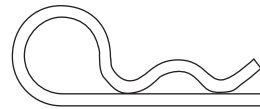

Hairpin Cotter

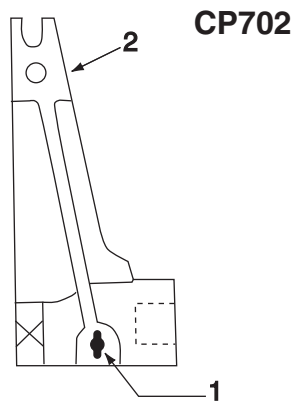

CP702

CP503 / 504

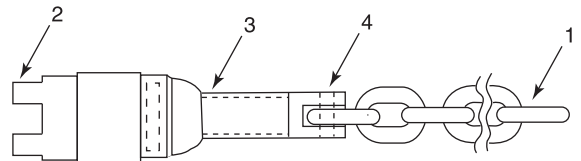

Part Numbers for CP503 / 504

Item No.	Description	Qty.	Part No.
1	2-ft. Chain	1	CF828066
1	6-ft. Chain	1	CP829066
2	Chain Nut	1	CF759120
3	Chain Screw	1	CF760028
4	Grooved Pin	1	CF830061
-	2-ft. Chain Assembly	1	CP503
-	6-ft. Chain Assembly	1	CP504

Part Numbers for CP702

Item No.	Description	Qty.	Part No.
1	Thumb Screw	2	CF589028
2	Coupling Clamp Fame	1	CP702

CP500 / CP501

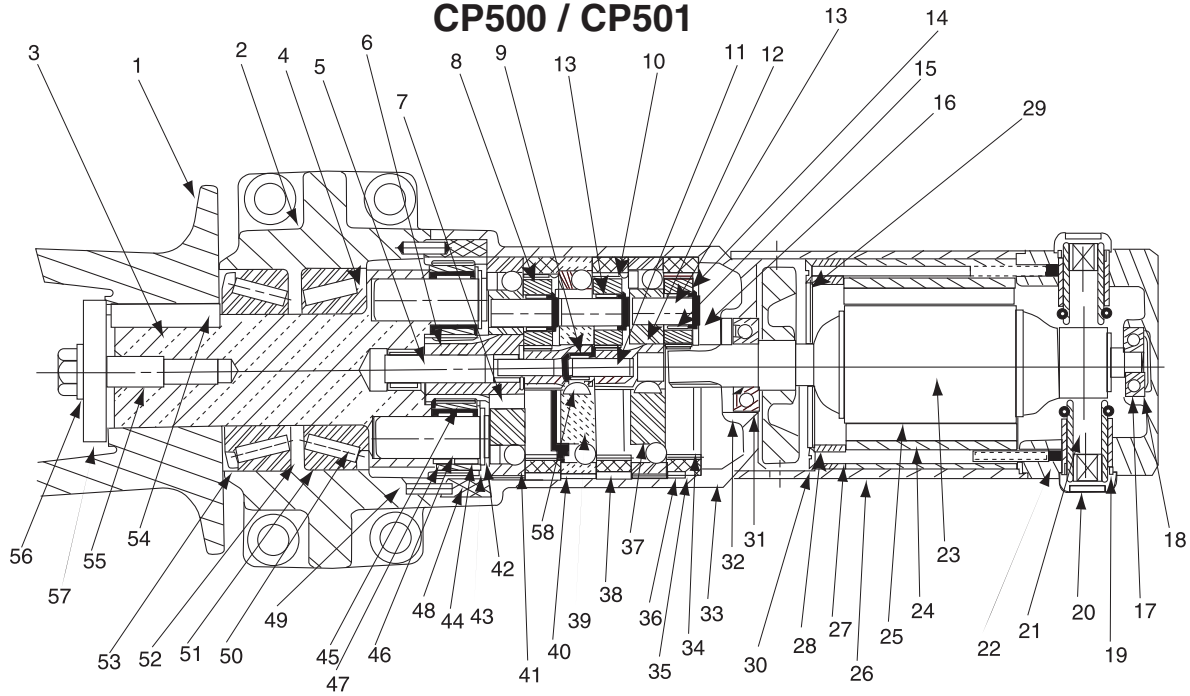

Parts List
Motor and Capstan Assembly

Item Number	Part Number	Number Req'd	Description
1	CA1016001	1	Capstan
2	CA1015001	1	Housing
3	CA1014001	1	Shaft
4	CA1013001	1	Bearing
5	CA1012001	1	Pin 1/2 x 1 3/4" lg.
6	CA1011001	1	Sun
7	CA1010001	1	Key
8	CA1009001	6	Planet
9	CA1008001	2	Bearing
10	CA1007001	6	Bearing
11	CA1006001	1	Pin 5/16" x 1" lg.
12	CA1005001	1	Sun
13	CA1004001	9	Pin
14	CA1003001	3	Bearing
15	CA1002001	3	Planet
16	CA1001001	3	Ring
17	CA1019001	1	Bearing
18	CA1018001	1	Spring
19	CA1020001	2	Holder
20	CA1021001	2	Cap
21	CA1022001	2	Brush
22	CA1023001	2	Screw 10-24 x 3/16"
23	CA1024001	1	Bushing
24	CA1025001	1	Field
25	Not Available	1	Armature
26	CA1027001	1	Housing
27	CA1028001	2	Screw 10-24 x 4 1/4"
28	CA1029001	2	Spacer

Parts List
Motor and Capstan Assembly

Item Number	Part Number	Number Req'd	Description
29	CA1030001	1	Insulator
30	CA1031001	1	Baffle
31	CA1032001	1	Bearing
32	CA1033001	1	Ring
33	CA1034001	1	Housing
34	CA1035001	3	Retainer
35	CA1036001	3	Gear
36	CA1037001	1	Key (1/8 x 1/4" lg)
37	CA1038001	1	Carrier Assy.
38	CA1039001	1	Key (1/8 x 5/8" lg)
39	CA1040001	1	Sprag Assy.
40	CA1041001	1	Key
41	CA1042001	1	Carrier Assy.
42	CA1043001	4	Ring
43	CA1044001	1	Retainer
44	CA1045001	4	Bearing
45	CA1046001	4	Planet
46	CA1047001	4	Pin
47	CA1048001	4	Washer
48	CA1049001	1	Gear
49	CA1050001	4	Pin 3/16 x 3/4" lg.
50	CA1051001	2	Cone
51	CA1052001	2	Cup
52	CA1053001	1	Spacer
53	CA1054001	1	Seal
54	CA1055001	1	Key
55	CA1056001	1	Screw 1/2-13 x 1 1/2" lg.
56	CA1057001	1	Washer 1/2"
57	CA1058001	1	Washer
58	CA1059001	2	Key

CP500-1 / CP501-1

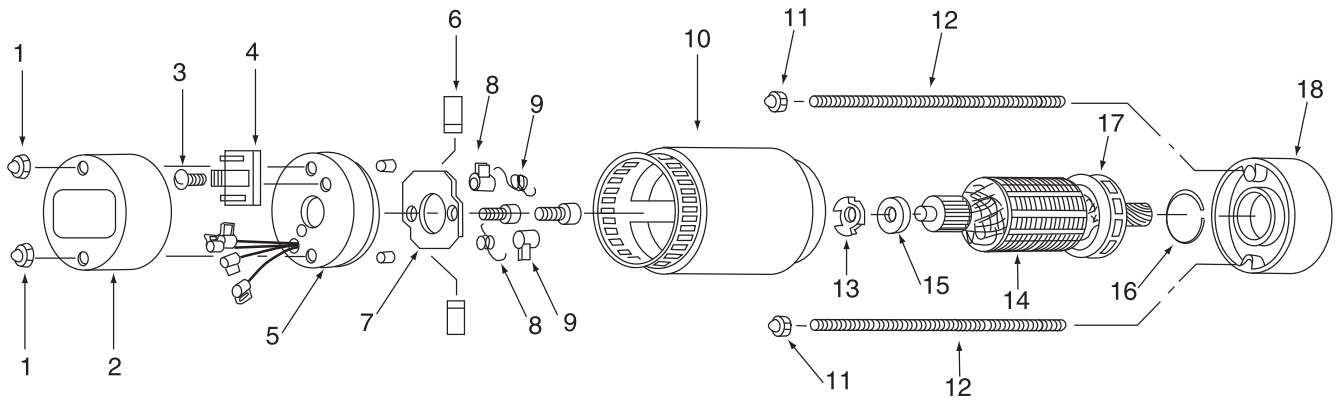
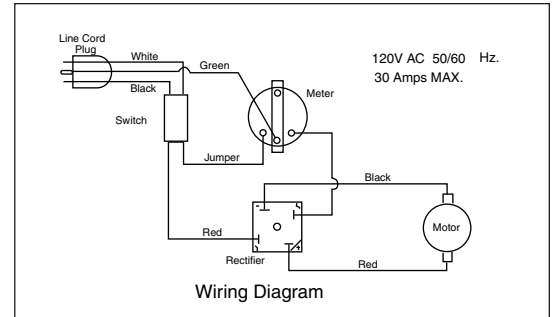

DA3231900 Cable Puller Motor Assembly (Effective on units built June '85 - August '90)

Parts List

Item Number	Description	Part Number	Qty.
1	Nut, Acorn	DA3218001	2
2	Cap, Motor	DA3217001	1
3	Screw, Rectifier	DA3214001	1
4	Rectifier, Bridge	DA3213001	1
5	End Bell, Brush	DA3212001	1
6	Bush, Motor	DA3210001	2
7	Plate, Brush	DA3209001	1
8	Flag, Disconnect	DA3215001	4
9	Spring, Brush	DA3211001	2
10	Housing, Motor	DA3219001	1
11	Nut, Housing	DA3216001	2
12	Stud, Housing	DA3206001	2
13	Spring, Armature	DA3208001	1
14	Armature, Motor	DA3205001	1
15	Bearing, Armature	DA3207001	1
16	Ring, Retaining	CA1033001	1
17	Bearing, Motor	DA3204001	1
18	Spacer, Housing	DA3220001	1

Part Numbers for CP621

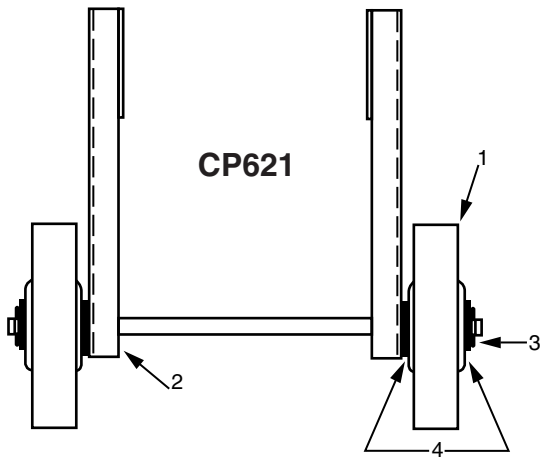

Item No.	Description	Qty.	Part No.
1	Wheel	2	C124106
2	Frame	1	CF787001
3	Hair Pin Clip	2	CF610058
4	Washer	4	CF612108

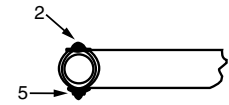

Part Numbers for CP701

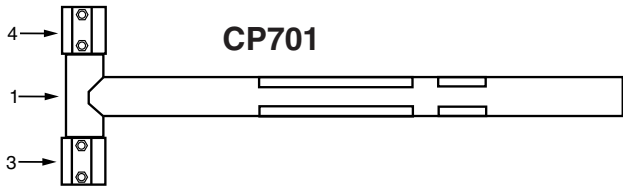

Item No.	Description	Qty.	Part No.
1	Extension	1	CB937900
2	Carriage Bolt	4	CB938028
3	Strap	4	CB939017
4	Pad	2	CB940046
5	Hex Nut	4	935043

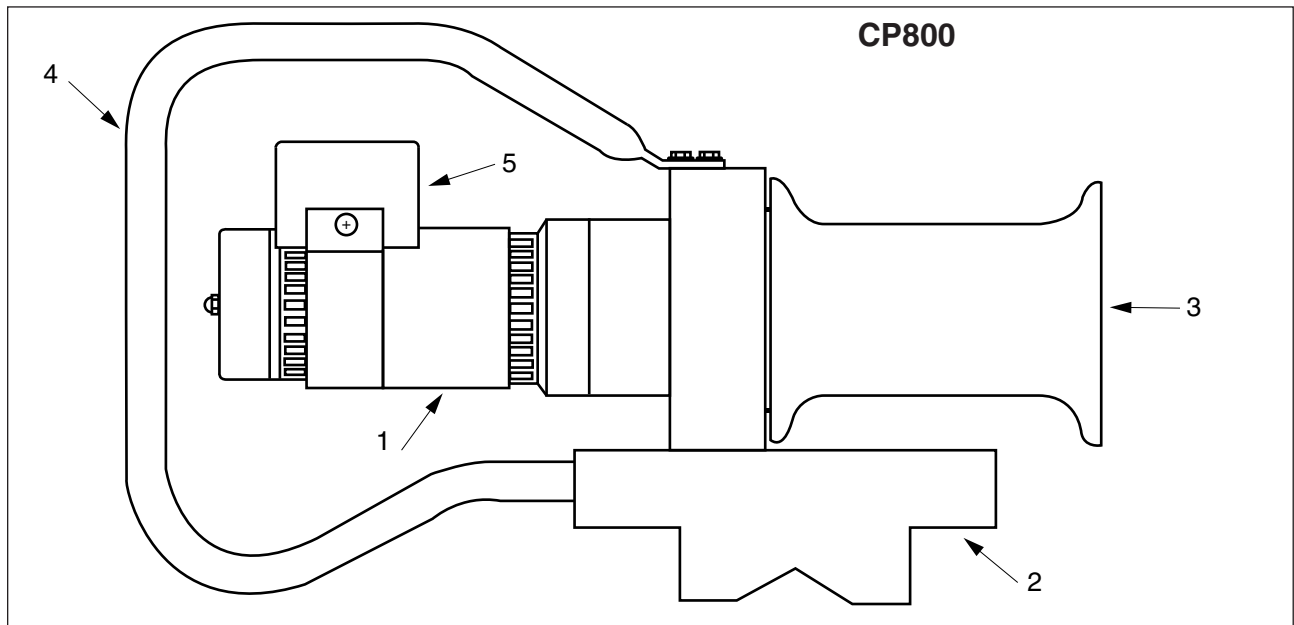

Part Numbers for CP800

Item No.	Description	Qty.	Part No.
1	Motor & Capstan (less bracket)	1	CP801
2	Base Mounting Bracket	1	Not sold separately
3	Capstan w/Hwde	1	CP806
4	Handle w/Hwde	1	CP20

Item No.	Description	Qty.	Part No.
5	Load Meter Assy.	1	CP10
-	Meter	1	CA1064001
-	Switch	1	CA1065001
-	Strap for CP500	1	CA1068001
-	Strap for CP500-1 & CP800	1	DA3221001
-	Line Cord	1	CA1069001

CP800/CP801

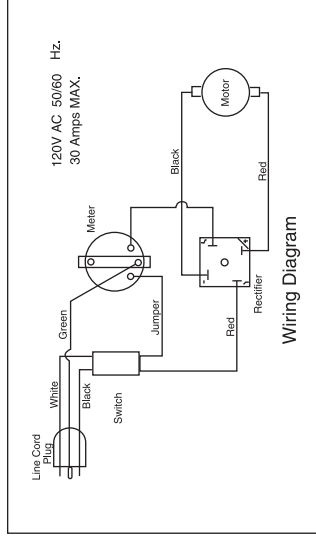
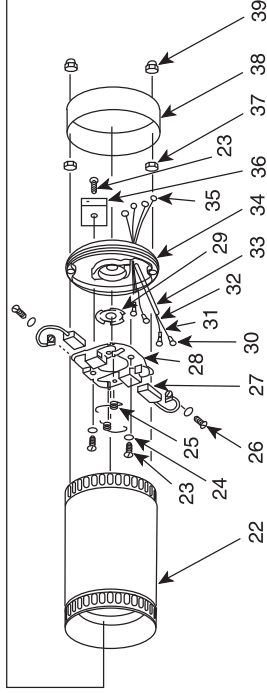
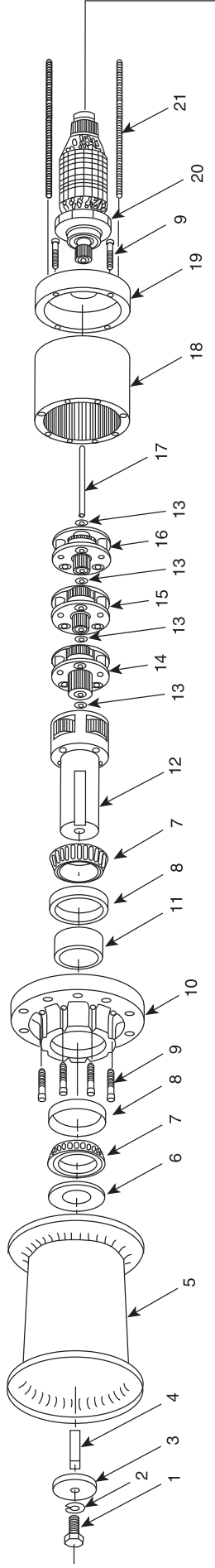

Notes

- CP800 series Power heads are identified from other models by:
 - Steel Capstan.
 - Mounted on welded steel bracket by circular flange & eight cap screws.
 - Overall length approximately 23 1/2".
- Output bearing preload to be measured on re-assembly. Housing (10), bearings, spacer (7), (8), (11) and shaft (12) should be assembled. Shaft should rotate when 10-20 in. lbs. torque is applied.
- Fill all bearing & carrier cavities with 4 fl. oz. of grease (40).
- Screws & nuts, use Loctite 242 on all threads.
- End play 0.010" min, 0.045" max. on disassembly. Note location & quantity of washers (13); re-assemble to match.
- Install screws (9), to 5-7 ft. lbs. Screw (1), to 30-50 ft. lbs.

CP801 Parts List

Item	Qty.	Part No.	Description
1	1	EA4201001	Screw, 1/2-13 x 1 1/4 lg grd. 5
2	1	CA1057001	Lockwasher, 1/2 Med.
3	1	CA1058001	Washer, Capstan
4	1	EA4202001	Key
5	1	EA4203001	Capstan, Steel
6	1	EA4204001	Seal, Nilos Ring
7	2	EA4205001	Cone, LM102949
8	2	EA4206001	Cup, LM102910
9	12	EA4207001	Screw, 1/4-20 x 1 1/2 lg.
10	1	EA4208001	Housing, Output
11	1	EA4209001	Spacer, Bearing
12	1	EA4210001	Shaft Assy., Output
13	4	EA4211001	Washer
14	1	EA4212001	Carrier, 3rd. Assy.
15	1	EA4213001	Carrier, 2nd. Assy.
16	1	EA4214001	Carrier, 1st. Assy.
17	1	EA4215001	Pin
18	1	EA4216001	Gear, Internal R74
19	1	EA4217001	Adapter, Motor
20	1	EA4218001	Armature Assy. Motor

* Not Shown

CP800 Parts List

Item	Qty.	Part No.	Description
21	2	EA4219001	Stud, 1/4 - 20 x 8 13/16 lg.
22	1	DA3219001	Shell, Magnet Assy
23	3	EA4220001	Screw, #8-32 x 1/2 lg.
24	4	EA4221001	Lockwasher, #8 Ext. Tooth
25	2	DA3211001	Spring, Brush
26	2	EA4222001	Screw, #8-32 x 3/8 lg. Brass
27	2	DA3210001	Brush, Motor
28	1	DA3209001	Plate, Brush
29	1	DA3208001	Spring, Preload
30	4	EA4223001	Terminal, Ring
31	2 ft.	EA4224001	Wire, 14AWG MTW Red
32	2 ft.	EA4225001	Wire, 14AWG MTW Black
33	3 in.	EA4226001	Tubing, Heat Shrink
34	1	DA3212001	Brush, End Bell
35	4	DA3215001	Terminal, Flag Disc.
36	1	DA3213001	Rectifier, Bridge
37	2	EA4227001	Nut, 1/4-20
38	1	DA3217001	Motor, Cap
39	2	DA3218001	Nut, Acorn 1/4 - 20
*40	4 oz.	EA4228001	Grease, Non Fluid HD-297

Optional Equipment



Optional Equipment

Catalog Number	Description
CP15	Foot Switch for remote operation
CP504	6-ft Chain Assembly
CP704	2" Conduit Coupling
CP705	2½" Conduit Coupling
CP10	Load Readout
CP806	Capstan

REPAIR AND SERVICE INSTRUCTIONS: For repair service and parts contact your nearest GARDNER BENDER Service Center. The Service Center will provide complete and prompt service on all GARDNER BENDER products.

PARTS AND SERVICE: For quality workmanship and genuine GARDNER BENDER parts, select an Authorized GB Service Center for your repair needs. Only repairs performed by an Authorized Service Center displaying the official GB Authorized sign are backed with full factory warranty. Contact GARDNER BENDER (414) 352-4160 for the name of the nearest GB Authorized Service Center.

WARRANTY: GARDNER BENDER warrants its products against defects in workmanship and materials for 1 year from date of delivery to user. Chain is not warranted. Warranty does not cover ordinary wear and tear, abuse, misuse, overloading, altered products or use of improper fluid.

WARRANTY RETURN PROCEDURE: When question of warranty claim arises, send the unit to the nearest GB Authorized Service Center for inspection, transportation prepaid. Furnish evidence of purchase date. If the claim comes under the terms of our warranty the Authorized Service Center will REPAIR OR REPLACE PARTS AFFECTED and return the unit prepaid.



6101 N. Baker Road, Milwaukee, WI 53209
Phone: (414) 352-4160 FAX (414) 352-2377