

RPS-0090 Rev. A 10/05

IMPORTANT: RECEIVING INSTRUCTIONS Visually inspect all components for shipping damage. If you find damage, notify the carrier at once. Shipping damage is NOT covered by warranty. The carrier is responsible for all repair or replacement costs resulting from damage in shipment.

GARDNER BENDER IS NOT RESPONSIBLE FOR DAMAGE OR INJURY CAUSED BY UNSAFE USE, MAINTENANCE OR THE APPLICATION OF ITS PRODUCTS. Please contact Gardner Bender for guidance when you are in doubt as to the proper safety precautions to be taken in designing and setting up your particular application.

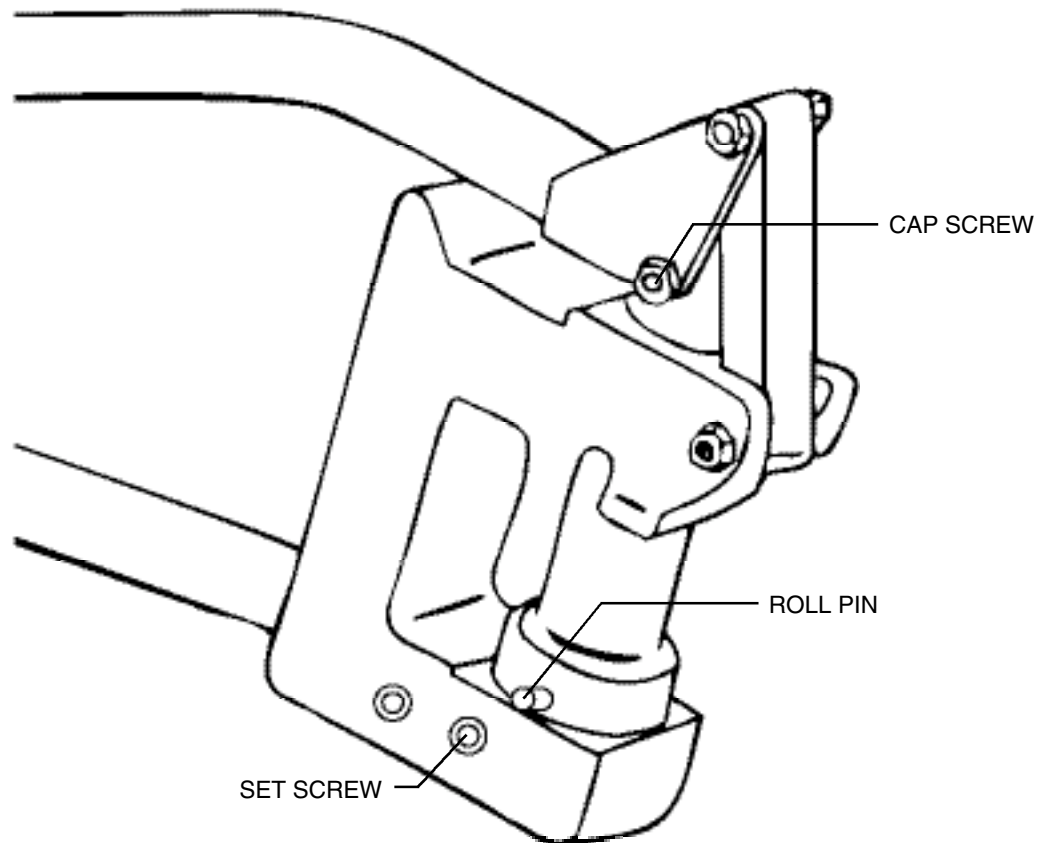

1. For removal of punch, both cap screw and roll pin must be extracted. Once cap screw has been withdrawn, swing handle out of the way and lift punch straight out. Reverse the above operation for installation of punch.
2. To Replace die, remove set screw (one closest to die). Lift die straight up and out. To install die reverse the above operation.

Parts Breakdown SP-6 Stud Punch

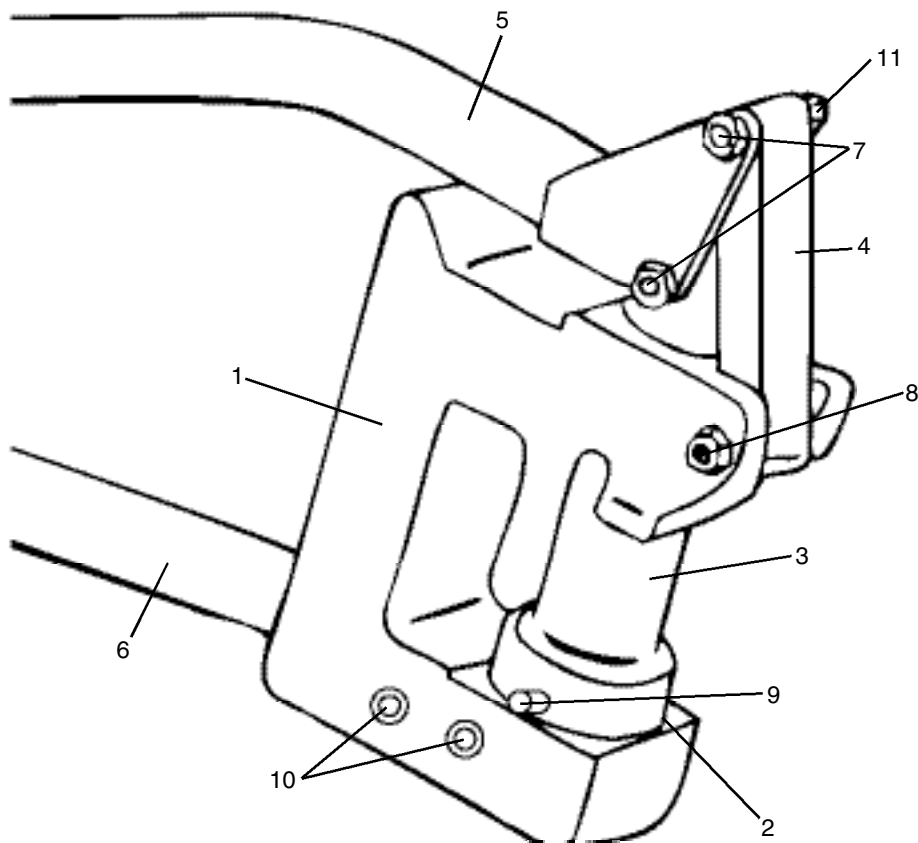

Item	Part No.	Description	Qty
1	43-17	Body	1
2	43-95	Die - 1" Conduit	1
3	43-52	Punch - 1"	1
4	43-221	Link	1
5	43-025	Upper Handle	1
6	43-903	Lower Handle	1
7	99-7024	Hex Head Cap Bolt	2
8	99-7023	Hex Head Cap Bolt	1
9	99-559	Roll Pin	1
10	99-8041	Socket Head Set Screw	2
11	99-629	Hex Locknut	3

REPAIR AND SERVICE INSTRUCTIONS: For repair service and parts contact your nearest Gardner Bender Service Center. The Gardner Bender Service Center will provide complete and prompt service on all Gardner Bender products.

PARTS AND SERVICE: For quality workmanship and genuine Gardner Bender parts, select an Authorized GB Service Center for your repair needs. Only repairs performed by an Authorized Service Center displaying the official GB Authorized sign are backed with full factory warranty. Contact Gardner Bender (414)352-4160 for the name of the nearest GB Authorized Service Center.

WARRANTY: Gardner Bender warrants its product against defects in workmanship and materials for 1 year from date of delivery to user. Warranty does not cover ordinary wear and tear, abuse, misuse, overloading, altered products or use of improper fluid.

WARRANTY RETURN PROCEDURE: When question of warranty claim arises, send the unit to the nearest GB Authorized Service Center for inspection, transportation prepaid. Furnish evidence of purchase date. If the claim comes under the terms of our warranty the Authorized Service Center will REPAIR OR REPLACE PARTS AFFECTED and return the unit prepaid.

GB
Gardner
Bender

PO Box 3241 • Milwaukee, WI 53201-3241 • 414-352-4160 • Fax 414-352-2377
6615 Ordan Drive • Mississauga, Ontario L5T 1X2 • 905-564-5749 • Fax 905-564-0305

RPS-0090 10/05