

IMPORTANT: RECEIVING INSTRUCTIONS

Visually inspect all components for shipping damage. If any shipping damage is found, notify carrier at once.

Shipping damage is NOT covered by warranty. The carrier is responsible for all repair or replacement costs resulting from damage in shipment.

SAFETY FIRST

IMPORTANT — USER SAFETY AND PROTECTION: In setting up systems to fit your operations, take care to select the proper components and design to insure appropriate integration with your operations and existing equipment. Observe safety measures to avoid the risk of personal injury and property damage from your application or system.

GB ELECTRICAL CANNOT BE RESPONSIBLE FOR DAMAGE OR INJURY CAUSED BY UNSAFE USE, MAINTENANCE OR APPLICATION OF ITS PRODUCTS. Please contact GB ELECTRICAL for guidance when you are in doubt as to the proper safety precautions to be taken in designing and setting up your particular application.

NOTE: The hydraulic cylinder in the knockout punch set is built and tested in compliance with ANSI B30.1. Use the cylinder to this specification.

⚠ WARNING

To prevent injury, keep hands away from the punch and die while punching holes. **NOTE:** To ensure ease of assembly, keep all threads clean and lightly oiled.

⚠ CAUTION

Do not drop objects on hydraulic hoses. An impact on the hose will weaken internal strands and lead to premature failure.

⚠ CAUTION

Avoid dropping the cylinder. During punch operation, support the cylinder to prevent it from falling after punching is completed.

⚠ CAUTION

To prevent thread damage, be sure punch is threaded onto the stud until the stud extends beyond the punch.

The following general instructions and guides will be helpful in determining if you have properly connected your hydraulic circuit:

1. Be sure all hydraulic connections, hoses, fittings, etc., are of the proper pressure rating and are fully tightened. Always use hoses and fittings specified by the manufacturer to insure correct pressure rated connections. Seal all NPT pipe connections with a high-grade pipe thread sealer.

⚠ WARNING

Teflon tape is an excellent thread sealer; however, if not properly applied, pieces may enter the hydraulic system and cause malfunctioning or damage.

2. **DO NOT** over-tighten connections. Connections need only be snug and leak free. Over-tightening can cause premature thread failure and may cause high pressure fittings or castings to split at lower than-rated-capacity.
3. Tighten all hydraulic couplers fully. Loose coupler connections will cause complete or partial blockage of oil flow from the pump to the cylinder.
4. Be sure all hydraulic hoses and fittings are connected to the proper inlet and outlet ports of the pump and cylinders.

Drilling Guide Holes

1. Mark the center position; drill a $\frac{1}{8}$ " pilot hole. Enlarge the hole with a $\frac{7}{16}$ " drill to provide pull rod clearance.
 - a. If working to close tolerances, mark the center position by scribing cross lines shown in figure 1.

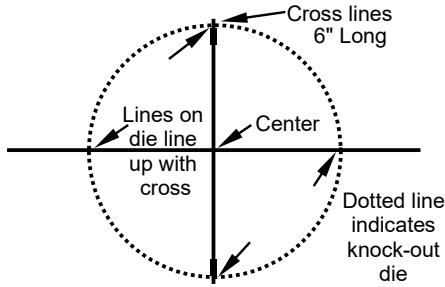

Drilling of Guide Hole

Figure 1

- b. When assembling the punch to the pull rod, align the cross marks with the four marks on the outer die surface.

NOTE: If pre-punched knockouts are already in the desired location, drilling a guide hole is not required.
2. For larger holes $\frac{3}{4}$ " to 3", the $\frac{1}{2}$ " punch is used to make the guide hole.

Punching $\frac{1}{2}$ " Holes

1. Thread the pull stud into the pull rod end until firmly seated. (Figure 2)

NOTE: The pull stud is only used with the $\frac{1}{2}$ " punch. The $\frac{1}{2}$ " punch is used to make guide holes for larger punch sizes.



Figure 2

2. Attach the pull rod to the cylinder by inserting the pull stud into the plunger opening and threading until the pull stud extends beyond the coupler end of the cylinder. (Figure 3)

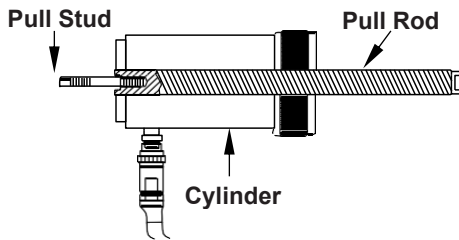

Figure 3

3. Attach the hydraulic hose to the hand pump and to the hydraulic cylinder.
4. Slide the $\frac{1}{2}$ " die over the pull stud, flat side toward the cylinder.
5. Insert the pull stud through the guide hole (Figure 4). Attach the $\frac{1}{2}$ " punch to the pull stud. Turn the punch until it is completely threaded onto the pull stud.

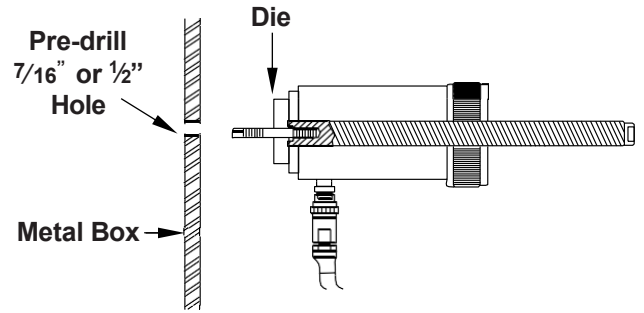

Figure 4

6. Close the pump release valve by turning it clockwise (Figure 5). Holding the punch set in position, work the pump handle until the punch completely penetrates the metal.

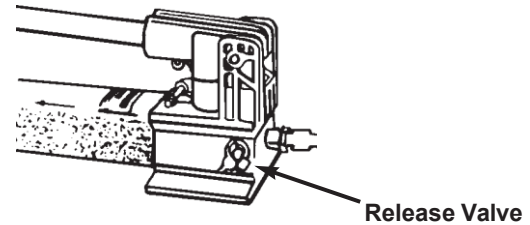

Figure 5

7. Remove the punch set from the hole. Turn pump release valve counterclockwise to open. Remove punch from pull stud. Slide the die off the pull stud. To remove the slug, turn die over and tap lightly on a solid object.

Punching Holes $\frac{3}{4}$ " Through 3"

1. Drill a $\frac{7}{16}$ " or $\frac{1}{2}$ " pilot hole; install the $\frac{1}{2}$ " punch and make guide hole. See "**Punching $\frac{1}{2}$ " holes**".
2. Remove the $\frac{1}{2}$ " punch and die. Also remove the pull stud.
3. Select the punch set needed. Slide the die over the pull rod (Figure 6).
4. Place the pull rod into the $\frac{1}{2}$ " guide hole; thread the punch onto the pull rod. Be sure the pull rod extends beyond the punch.
5. Operate the hand pump until the punch penetrates the metal. Open the pump release valve. Remove the punch and die from the pull stud. Remove the slug.

CAUTION

To avoid excessive wear and tear on the pull rod threads during punching, center the pull rod accurately so that it does not rest against the metal edge of the guide hole. Also, be sure that all points of the punch are in uniform contact with the metal surface when starting to punch.

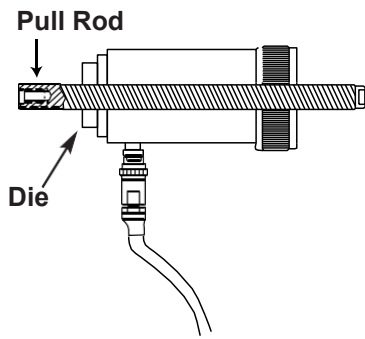

Figure 6

NOTE: It will be necessary to turn the pull rod until it extends further beyond the cylinder (coupler end).

Punching 3½" and 4" Holes

1. Larger punch sizes require a 115/16" diameter guide hole (use 1½" punch and die) and a KC3540 converter.

2. Drill a 7/16" pilot hole in the metal. Use the 1½" punch and die set to make the guide hole. See paragraph "**Punching holes ¾" through 3"**".

3. Remove the 1½" punch and die. Install the 3½", 4", 5", or 6" die over the pull rod. (See Figure 7)

4. Install the KC3540 converter on the inside of the punch. (Figure 7)

CAUTION

Do not install the converter (KC3540) on outside of punch. Damage to the pull rod would result from incorrect converter installation.

5. Place the pull rod into the guide hole. Install the punch on the pull rod and turn until the converter is into the guide hole.

6. Close the pump release valve. Work the pump handle until all points of the punch completely penetrate the metal.

CAUTION

The converter requires a 115/16" diameter or larger guide hole (use the 1½" knockout).

Do not assemble converter on outer side of punch, or pull rod will bend during operation.

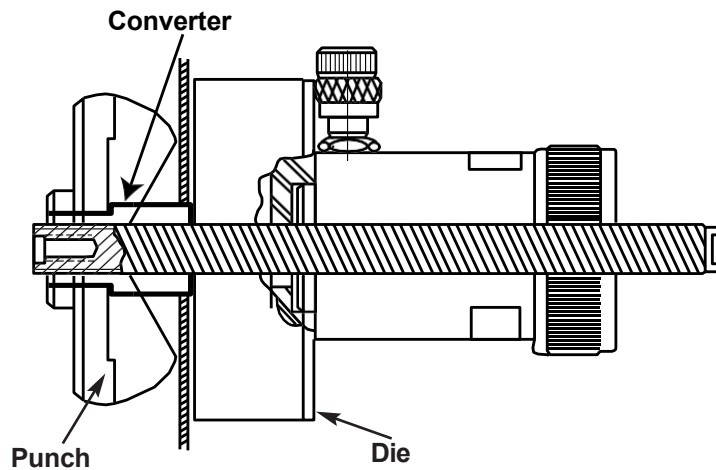

Figure 7

REPAIR AND SERVICE INSTRUCTIONS: For repair service and parts contact your nearest GB ELECTRICAL Service Center. The Service Center will provide complete and prompt service on all GB ELECTRICAL products.