

IMPORTANT: RECEIVING INSTRUCTIONS: Visually inspect all components for shipping damage. If any shipping damage is found, notify carrier at once. Shipping damage is NOT covered by warranty. The carrier is responsible for all repair or replacement costs resulting from damage in shipment.

SAFETY FIRST

IMPORTANT USER SAFETY AND PROTECTION: In setting up systems to fit your operations, care must be taken to select the proper components and design to insure appropriate integration with your operations and existing equipment and that all safety measures have been taken to avoid the risk of personal injury and property damage from your application or system.

GB ELECTRICAL, INC. CANNOT BE HELD RESPONSIBLE FOR DAMAGE OR INJURY CAUSED BY UNSAFE USE, MAINTENANCE OR APPLICATION OF ITS PRODUCTS. Please contact GB's technical service department for assistance if you are in doubt as to the proper safety precautions essential to designing and setting up your particular application.

The CS400 Cylinder Support is used only with the Ultra Eegor™ models B400L and B400DL when mounting them on the BE400 Table Assembly.

CAUTION Weight of the B400L Cylinder and Frame is approximately 125 lbs. Make sure help or equipment is available to lift the unit 3 ft high.

1. The B400L and B400DL bender assembly is mounted to the top of the BE400 table. Position the bender on the table; make sure the cylinder is at the wheel end of the table. Slide the conduit support extension under the cylinder. Raise the extension up to support the cylinder during assembly installation. Figure 1.

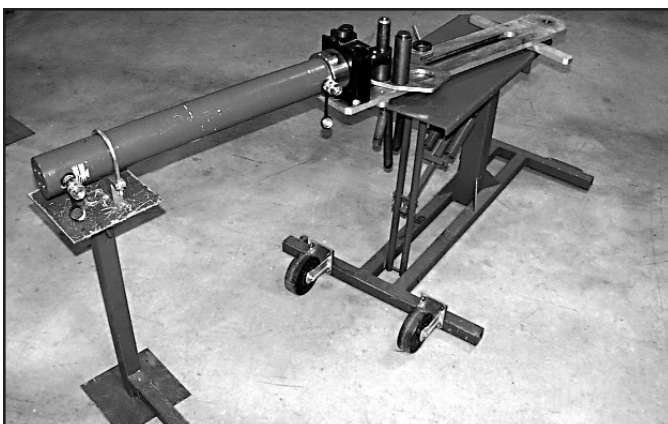

Fig. 1

2. Remove the double anchor pin. Push on the cylinder assembly to slide the cylinder and block forward. Align the block with the holes marked 4" - 3½". Install the anchor pin. Figure 2.



Fig. 2

3. Slide the front stabilizer bar over the side of the table so the mounting bolts can be removed. Leave the stabilizer in position. Move the cylinder end of the bender to gain access to mounting bolts connecting the round pads under the frame. Remove each bolt. Position the lower frame and pads over the holes in the table top.

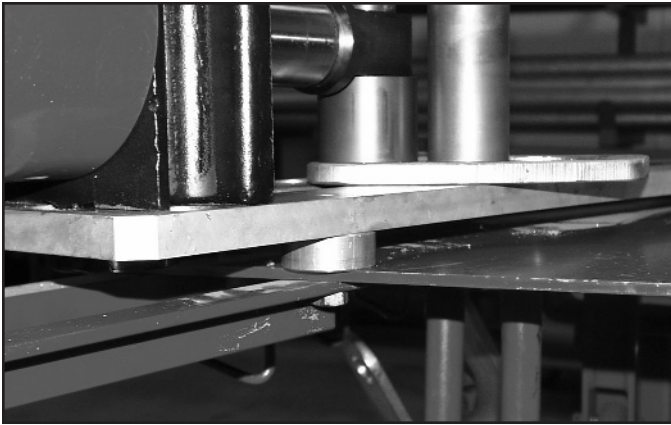

Fig. 3

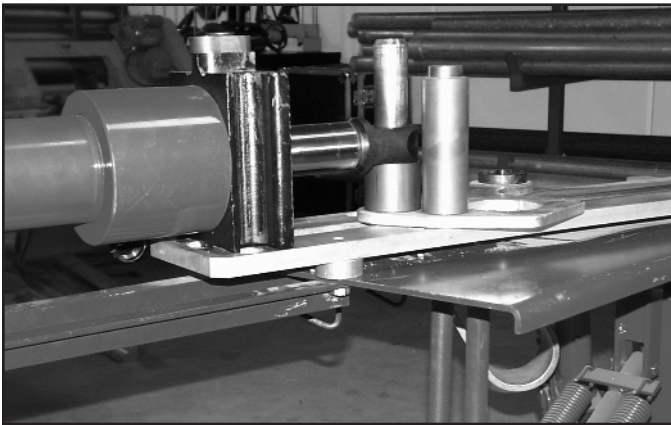

Fig. 4

4. Fasten the lower frame and stabilizer bar to the table. Use two 1/2 - 13 UNC x 1 3/4" long bolts installed from the underside of the table. Do not fully tighten the bolts. Figure 3 & 4.

5. Position the two legs of the cylinder support under the cylinder end of the table. Align the holes in the table and fasten the support, mounting pads and lower frame with two 1/2 - 13 UNC x 1 3/4" long hex head bolts.

6. Tighten all four bender-to-frame mounting bolts.

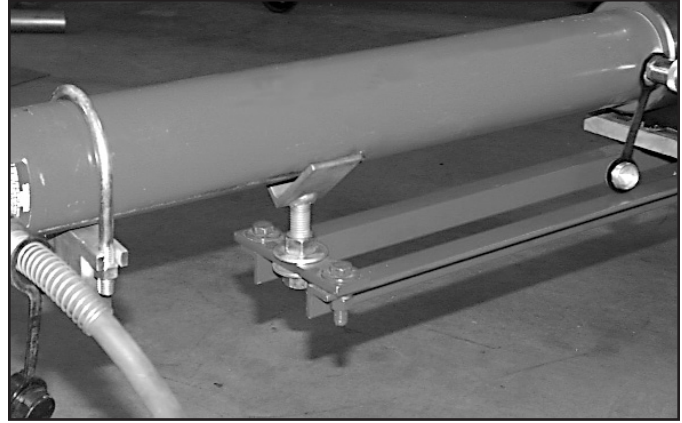

Fig. 5

7. Adjust the cylinder support "V" block until the cylinder is firmly supported and level. Figure 5.

REPAIR AND SERVICE INSTRUCTIONS: For repair service and parts contact your nearest GB ELECTRICAL Service Center. The Service Center will provide complete and prompt service on all GB ELECTRICAL products.

PARTS AND SERVICE: For quality workmanship and genuine GB ELECTRICAL parts, select an Authorized GB Service Center for your repair needs. Only repairs performed by an Authorized Service Center displaying the official GB Authorized sign are backed with full factory warranty. Contact GB Electrical (414) 352-4160 for the name of the nearest GB Authorized Service Center.

WARRANTY: GB ELECTRICAL, INC. warrants its products against defects in workmanship and materials for 1 year from date of delivery to user. Chain is not warranted. Warranty does not cover ordinary wear and tear, abuse, misuse, overloading, altered products or use of improper fluid.

WARRANTY RETURN PROCEDURE: When question of warranty claim arises, send the unit to the nearest GB Authorized Service Center for inspection, transportation prepaid. Furnish evidence of purchase date. If the claim comes under the terms of our warranty the Authorized Service Center will REPAIR OR REPLACE PARTS AFFECTED and return the unit prepaid.



GB Electrical, Inc.
An Applied Power Company

6101 N. Baker Road, Milwaukee, WI 53209
Phone: (414) 352-4160 FAX (414) 352-2377

RPS-0130 Rev. A 03/07